



Accelerating the World of Cooking™

Service Manual

FOR THE TURBOCHEF® RESIDENTIAL SINGLE AND DOUBLE WALL OVENS



For further information, call
866.447.3783
or
+1 214.379.6000

The information contained in this manual is important for the proper installation, use, maintenance, and repair of this oven. Follow these procedures and instructions to help ensure satisfactory baking results and years of trouble-free service.

Errors – descriptive, typographic, or pictorial – are subject to correction. Specifications are subject to change without notice.

PLEASE CAREFULLY READ THIS MANUAL AND RETAIN IT FOR FUTURE REFERENCE.

©2008 TurboChef Technologies, Inc.

Table Of Contents

Safety Instructions

Safety Precautions	i
To Reduce the Risk of Fire in the Cook Cavity	ii
Precautions to be Observed Before and During Servicing to Avoid Possible Exposure to Excessive Microwave Energy	ii
Grounding Instructions	ii
Do Not Touch Heating Elements or Interior Surfaces of Oven	ii
Power Connections	ii
Self-Cleaning Oven Guidelines	ii
RF Interference Considerations	iii

Section 1 - Specifications and Installation

Theory of Operation	1.1
Catalytic Converter	1.1
Certifications	1.1
Electrical Specifications	1.1
Dimensions - Double Wall Oven	1.2
Dimensions - Single Wall Oven	1.2
Installation	1.3
Installation Safety Instructions	1.3
Double Wall Oven Cabinet Dimensions	1.5
Single Wall Oven Cabinet Dimensions	1.5
Installing the Oven	1.5

Section 2 - Oven Controls and Cooking - The Speedcook Oven

Speedcook Oven Controls	2.1
Cook Modes	2.2
Air-Crisp	2.2
Bake	2.2
Broil	2.2
Dehydrate	2.2
Favorites	2.2
Roast	2.3
Toast	2.3
Favorites Cooking	2.3
Cooking a Recently Prepared Dish	2.3
Cooking a "Favorite" Dish	2.3
Using the Convection Bake Function	2.4
Using the Defrost Function	2.4
Using the Microwave Function	2.4
Basic Cooking	2.5
Mode 1: Oven Off	2.5
Mode 2: Select a Food Item	2.5

Mode 3: Confirm Settings	2.6
Mode 4: Preheat	2.6
Mode 5: Ready to Cook	2.6
Mode 6: Cooking	2.6
Mode 7: 80% Complete	2.6
Mode 8: 100% Complete	2.7
Mode 9: Remove Food from Oven	2.7
Adjusting a Recipe's Cook Time	2.8
Adjusting a Cook Temperature	2.8
The Advanced Cook Mode	2.8
Saving to Favorites	2.9
Renaming a Dish (in Favorites)	2.10
Deleting a Dish (from Favorites)	2.10
Reheat Setting	2.10
Self-Clean Mode - Speedcook Oven	2.10

Section 3 - Oven Controls and Cooking - Lower Oven (Double-Wall Oven Only)

Lower Oven Controls	3.1
Cook Modes	3.2
Bake	3.2
Broil	3.2
Convection Bake	3.2
Convection Roast	3.2
Roast	3.2
Warm Setting	3.2
Proof Setting	3.2
Basic Cooking	3.3
The Sabbath Mode	3.3
Self Clean Mode	3.4

Section 4 - Info Mode

Overview of the Info Mode	4.1
Adjusting Oven Sounds	4.1
Adjusting Display Settings	4.2
Adjusting the Oven's Units & Measurements	4.2
Accessing Help Topics and General Cooking Information	4.2
Updating the Oven Software	4.3
Backing Up/Restoring Favorites	4.3
Accessing the Version Information	4.4
Installer Setup	4.4
Top (or Single Wall) Oven Component Tests	4.4
Bottom Oven Component Tests	4.4
Oven Configuration	4.4
AC Voltage Configuration	4.4
Simulation/Demo State, and printf Mask	4.4

Section 5 - Oven Systems

Convection System - Speedcook Oven	5.1
Blower Motor (Bottom)	5.1
Blower Motor (Top)	5.1
Blower Motor Controller (BMSC)	5.1
Heater Assembly	5.1
Jetplate (Bottom)	5.1
Jetplate (Top)	5.1
Stirrer Motor and Assembly	5.1
Convection System - Lower Oven (Double Wall Oven Only)	5.2
Broil Element	5.2
Bake Element	5.2
Convection Element	5.2
Convection Fan	5.2
Speedcook Oven Door	5.2
Removing/Reinstalling the Speedcook Oven Door	5.2
Door Skin Replacement	5.3
Left Lock Motor Assembly	5.3
Right Lock Motor Assembly	5.3
Measuring RF Leakage for Microwave Safety	5.4
Halogen Light Assembly	5.5
Lower Oven Door (Double Wall Oven Only)	5.5
Removing/Reinstalling the Lower Oven Door	5.5
Halogen Bulb Replacement	5.6
Microwave System	5.6
Doubler Circuit, Voltage	5.6
High-Voltage Capacitors	5.6
High-Voltage Diode	5.6
High-Voltage Transformers	5.7
Wiring a High-Voltage Transformer	5.7
Magnetrons	5.7
Stirrer Motor and Assembly	5.7
Waveguides	5.7
Control System	5.8
Air Switch (Single Wall Oven)	5.8
Clock	5.8
Control Board	5.8
CookWheel Control	5.8
Display, Lower Oven	5.8
Attaching the Lower Display Cable	5.8
Display, Speedcook Oven	5.9
Electrical Compartment Cooling Fans	5.9
EMI Filter	5.9
Fuses	5.9
High Limit Thermostats	5.9
Latch Mechanism (Lower Oven)	5.9
Light Switch, Control Panel	5.9

M.O.V. Filter	5.9
Magnetron Cooling Fan	5.10
Magnetron Thermostats	5.10
Power Supply, 12 VDC	5.10
Power Supply, 24 VDC	5.10
Relay Board (Gen 2 Oven)	5.10
Relay - K2 Monitor (Gen 1 Oven)	5.10
Relay - K3 T1 HV Transformer (Gen 1 Oven)	5.10
Relay - K4 T2 HV Transformer (Gen 1 Oven)	5.10
Relay - K5 Mag Cooling Fan (Gen 1 Oven)	5.10
Relay - K6 Right Side Door Lock (Gen 1 Oven)	5.10
Relay - K7 Left Side Door Lock (Gen 1 Oven)	5.10
Relay - K8 Preheat (Gen 1 Oven)	5.10
Relay - K9 L2 Speedcook Heating Elements	5.11
Relay - K10 Lower Door Lock (Gen 1 Oven)	5.11
Relay - K13 L2 Lower Heating Elements (Double Wall Oven Only)	5.11
RJ Cables	5.11
RTD	5.11
SD Card	5.11
Selector Switches	5.11
Solid State Relay - K1 L1 Speedcook Heating Elements	5.12
Solid State Relay - K11 Bake and Convection Elements (Double Wall Oven Only)	5.12
Solid State Relay - K12 Broil Elements: Inner and Outer (Double Wall Oven Only)	5.12
Speaker	5.12
Temperature Switch	5.12
Transformer, Clock, 12 VAC	5.12
Thermostat, Cook Cavity	5.12
Thermostat, Cooling Fan Control	5.12
USB Port	5.12
Connecting the USB Board (Gen 1 Oven)	5.12
Wiring Harness	5.13
Exhaust System	5.13
Catalytic Converter	5.13
Exhaust Blower	5.13
Vent Catalyst	5.13

Section 6 - Troubleshooting

Overview of Troubleshooting	6.1
Error Screens	6.1
Oven Door Open (Gen 1)	6.1
Oven Door Open (Gen 2)	6.2
Cooling Fan Failure (Gen 1)	6.2
Cooling Fan Failure (Gen 2)	6.2
Temperature Control Failure	6.2
Magnetron Failure	6.3
Magnetron Failure Troubleshooting	6.3
Blower Failure	6.3
Blower Failure Troubleshooting	6.4

Oven Over Temperature	6.4
Component Testing and Troubleshooting	6.4
Control System	6.4
Clock Assembly	6.4
Control Board	6.4
CookWheel Control (Speedcook Oven)	6.4
EMI Filter	6.5
Oven Mode Switch (Lower Oven)	6.5
Power Supply, 12 VDC	6.5
Power Supply, 24 VDC	6.5
RTD	6.6
Transformer, 12 VAC (Gen 1)	6.6
Transformer, 12 VAC (Gen 2)	6.6
Halogen Light System	6.7
Light Switch, Control Panel (Manual)	6.7
Light Switch, Speedcook Oven (Door Actuated)	6.7
One Speedcook Oven Light is Out	6.7
Both Speedcook Oven Lights are Out	6.7
Both Speedcook Oven and Both Lower Oven Lights are Out (Double Wall Oven)	6.7
Cooling System	6.7
Cooling Fan Overview (Gen 1)	6.7
Cooling Fan Overview (Gen 2)	6.8
Troubleshooting Cooling Fans (Gen 1)	6.8
Troubleshooting Cooling Fans (Gen 2)	6.9
Air Impingement Systems	6.9
Blower Motors, Speedcook Oven	6.9
Convection Fan, Lower Oven	6.10
Microwave System	6.10
Testing a Capacitor	6.10
Testing a High-Voltage Diode	6.10
Testing a High-Voltage Transformer	6.11
Testing a Magnetron for an Open/Shorted Filament	6.11
Heating System, Speedcook Oven	6.11
Heater Element, Speedcook Oven	6.12
No Heat	6.12
Oven is Heating up Very Slowly	6.12
Testing for Control Voltage to the K1 SSR	6.12
Testing for Control Voltage to the K8 Relay (Gen 1)	6.13
Testing Relay 14 (Pre-Heat) Operation (Gen 2)	6.13
Testing for a K9 Relay that is Stuck Open	6.13
Testing for a K1 SSR that is Stuck Open	6.13
Heating System, Lower Oven	6.13
Lower Oven Heating Element Specifications	6.14
No Heat/Slow to Heat	6.14
Testing for Voltage to the K11 SSR	6.14
Testing for Voltage to the K12 SSR	6.14
Testing for a K11 SSR that is Stuck Open	6.15
Testing for a K12 SSR that is Stuck Open	6.15
Testing for a K13 Relay that is Stuck Open	6.15

Section 7 - Schematics

Gen 1 Speedcook Oven Schematic	7.1
Gen 1 Bottom Oven Schematic	7.2
Gen 2 Speedcook Oven Schematic	7.3
Gen 2 Bottom Oven Schematic	7.4
Single Wall Oven Schematic	7.5
RWD/RWS Gen 2 Control Board	7.6
RWD/RWS Gen 2 Relay Board	7.7

Appendix - Replacing Oven Components

Comprehensive Table of Oven Components	A.1
Component and Assembly Location, DWO Gen 1 and Gen 2	A.6
Removing the Oven	A.6
Component and Assembly Location, SWO	A.8
Removing the Oven	A.8
Front Trim Assembly Detail	A.10
Front Trim Assembly Removal	A.10
Control Housing Detail	A.12
Upper Electrical Compartment, DWO Gen 1	A.13
Differentiating Between DWO Gen 1 and DWO Gen 2	A.13
Upper Electrical Compartment, DWO Gen 2 and SWO	A.16
Differentiating Between DWO Gen 1 and DWO Gen 2	A.16
Controls Assembly Detail, DWO Gen 1, DWO Gen 2, and SWO	A.18
Mag Air Diverter Assembly Detail, DWO Gen 1, DWO Gen 2, and SWO	A.20
Relay and Relay/Power Assembly Detail, DWO Gen 1, DWO Gen 2, and SWO	A.21
Lower Electrical Compartment Detail, DWO Gen 1 and DWO Gen 2	A.22
Differentiating Between DWO Gen 1 and DWO Gen 2	A.22
Speedcook Oven Cavity Component Detail, DWO Gen 1, DWO Gen 2, and SWO	A.24
Lower Oven Cavity Component Detail, DWO Gen 1 and DWO Gen 2	A.28

READ ALL INSTRUCTIONS BEFORE USING

⚠ WARNING: For your safety, the information in this manual must be followed to minimize the risk of fire or explosion, electric shock, or to prevent property damage, personal injury, loss of life, or excessive exposure to microwave energy.

Safety Precautions

When using electrical appliances, basic safety precautions should be followed, including the following:

⚠ WARNING: To reduce the risk of burns, electric shock, fire, injury to persons or exposure to microwave energy:

- Read all instructions before using this appliance.
- Read and follow “Precautions to Avoid Possible Exposure to Excessive Microwave Energy” outlined later on page ii.
- This appliance must be grounded. See Grounding Instructions on page ii for further details.
- Install or locate this appliance only in accordance with the provided installation instructions. Be sure the appliance is properly installed and grounded by a qualified technician.
- Always place oven racks in desired location while the oven is cool. If rack must be moved while oven is hot, DO NOT let potholder contact hot heating element in the oven. Oversized foods or oversized metal utensils should not be inserted in a microwave/toaster oven as they may create a fire or risk of electric shock.
- Some products, such as whole eggs and sealed or unopened food containers – for example, sealed glass jars – may explode due to a build up of pressure and SHOULD NOT be heated in this oven.
- Use care when opening oven door – let hot air or steam escape before removing or replacing food.
- Use only microwaveable heat-resistant cookware – for example: Pyrex® Glassware, Stoneware, standard oven cooking utensils – in the Speedcook section of this appliance.
- This appliance should be serviced only by qualified service personnel. Contact TurboChef® Customer Service (866-447-3783) for examination, repair, or adjustment.
- Use this appliance only for its intended purpose as described in this manual. DO NOT use corrosive chemicals or vapors in this appliance. This oven is specifically designed to heat or cook food and is not intended for laboratory or industrial use. DO NOT use the oven to warm or heat a room.
- DO NOT store flammable materials in this oven or near surface units. DO NOT store any materials, other than manufacturer’s recommended accessories, in this oven when not in use.
- DO NOT attempt to repair or replace any part of this oven unless it is specifically recommended in this manual or the Use and Care Guide.
- DO NOT use aluminum foil to cover contents, racks, or any part of the Speedcook oven. Prolonged use can cause overheating and damage the microwave components. Use in the bottom oven of a Double Wall oven is permissible; however, do not lay foil on the bottom of the oven.
- DO NOT use moist or damp potholders. Moist or damp potholders on hot surfaces may result in burns from steam. DO NOT let potholder touch hot heating elements. DO NOT use a towel or other bulky cloth.
- DO NOT allow children to operate without adult supervision. Children should not be left alone or unattended in the area where this appliance is in use. They should never be allowed to sit or stand on any part of the oven.
- DO NOT operate this appliance wearing loose-fitting or hanging garments.
- DO NOT operate this appliance if it has a damaged cord or plug, is not working properly, or has been damaged or dropped.
- DO NOT cover or block any openings on this appliance. Keep oven vent ducts unobstructed.
- DO NOT store this appliance outdoors.
- DO NOT use this appliance near water – e.g., in a wet basement or near a swimming pool.
- DO NOT use water on grease fires. Smother fire or flame or use dry chemicals or foam extinguisher.

To Reduce the Risk of Fire in the Cook Cavity:

- Use only oven-suitable containers in the oven. DO NOT use paper products in either oven.
- Remove wire twist-ties from paper or plastic bags being placed in the oven. For oven cooking bags – DO NOT use wire twist-ties to close the bag.
- If materials inside the oven should ignite, keep the oven door closed, turn the oven off and shut off power at the fuse or circuit breaker panel. If the door is opened, the fire may spread.
- DO NOT cook items wrapped in cling wrap or plastic film.
- DO NOT overcook food. Carefully attend to the oven if paper, plastic, or other combustible materials are placed inside the oven to facilitate cooking.

Precautions to be Observed Before and During Servicing to Avoid Possible Exposure to Excessive Microwave Energy

- a) DO NOT operate or allow the oven to be operated with the door open.
- b) Make the following safety checks on all ovens to be serviced before activating the magnetron or other microwave source, and make repairs as necessary: (1) interlock operation, (2) proper door closing, (3) seal and sealing surfaces (arcing, wear, and other damage), (4) damage to or loosening of hinges and latches, (5) evidence of dropping or abuse.
- c) Before turning on microwave power for any service test or inspection within the microwave generating compartments, check the magnetron, wave guide or transmission line, and cavity for proper alignment, integrity, and connections.
- d) Any defective or misadjusted components in the interlock, monitor, door seal, and microwave generation and transmission systems shall be repaired, replaced, or adjusted by procedures described in this manual before the oven is released to the owner.
- e) A microwave leakage check to verify compliance with the Federal performance standard should be performed on each oven prior to release to the owner.

Grounding Instructions

This appliance must be connected to a grounded, metallic, permanent wiring system, or an equipment grounding conductor should be run with the circuit conductors and connected to the equipment grounding terminal or lead on the appliance.

Do Not Touch Heating Elements or Interior Surfaces of Oven

Heating elements may be hot even though they are dark in color. Interior surfaces of an oven become hot enough to cause burns. During and after use, do not touch, or let clothing or other flammable materials contact heating elements or interior surfaces of oven until they have had sufficient time to cool.

Power Connections

To avoid potential hazards, only the manufacturer, its service agent, or a similarly-qualified person should replace a damaged power cable. Flexible conduit, conductors and connectors are supplied by the manufacturer. The oven must be connected using the flexible conduit and conductors provided.

Self-Cleaning Oven Guidelines

Clean the oven only in accordance with the guidelines provided on this page, page 2.10, and page 3.4.

- Before self-cleaning the oven, remove broiler pan, grid, racks, and other cookware. Clean only parts listed in manual.
- Listen for fan – a fan noise should be heard sometime during the cleaning cycle. If not, call Customer Service (866.447.3783) before self-cleaning again.
- DO NOT clean the door gasket. The door gasket is essential for a good seal. Care should be taken not to rub, damage or move the gasket.
- DO NOT use oven cleaners. No commercial cleaner or oven liner protective coating of any kind should be used in or around any part of the oven. Residue from oven cleaners will damage the inside of the oven when the self-clean mode is used.
- If the oven is malfunctioning in the self-clean mode, turn off or disconnect the appliance from the power supply and have it serviced by a qualified technician.
- Complete instructions on the operation of the self-clean mode can be found on pages 2.10 and 3.4.

RF Interference Considerations

The appliance has been tested and was determined to be in compliance with applicable portions of FCC part 18 requirements and with the protection requirements of Council Directive 89/336/EEC on the approximation of the laws of the Member States relating to electromagnetic compatibility at the time of manufacture. However, some equipment with sensitivity to signals below these limits may experience interference.

If any equipment experiences interference, the following steps should be considered:

- Increase the physical distance between the sensitive equipment and this oven.
- If the sensitive device can be grounded, do so following accepted grounding practices.
- If battery-powered microphones are being affected, ensure that the batteries are fully charged.
- Keep sensitive equipment on separate electrical circuits if possible.
- DO NOT route intercom wires, microphone wires, or speaker cables near the oven.

*This page intentionally
left blank.*

Section 1
Specifications and Installation

Theory of Operation

The TurboChef® Residential Speedcook oven combines high-speed forced air impingement and microwave energy to cook food up to 15 times faster than a conventional oven. The re-circulating air transfers heat to the food and then passes through a catalytic converter where excess grease and odors are removed and combusted. Simultaneously, precise bursts of microwave energy cook the food from the inside out. This combination of heating technologies quickly cooks food and seals moisture to help ensure chef-quality results in a fraction of the time.

This manual includes instructions for servicing, troubleshooting, installing, cleaning, and operating the TurboChef Residential double and single wall ovens. If you have questions not addressed in this manual, contact Technical Service (866.447.3783, +1 214-379-6000) or your Authorized Distributor.

Catalytic Converter

The catalytic converter removes odors and grease from the air inside the cook cavity. It is also responsible for limiting and removing any smoke from the cavity in case of a spill. Do not use oven cleaner when cleaning the Speedcook oven, as the catalyst can become damaged by the use of caustic cleaners, resulting in a non-warranty service call. See pages 2.10, and 3.4 for approved self-cleaning instructions.

Certifications

cETLus



Electrical Specifications

Phase: Single

Frequency: 60 Hz

Current: 50 amp (DWO) / 30 amp (SWO)

Cord: 4-wire (inc. ground)

Voltage: 208 or 240 (depending on model)

Connection: 5½ ft flex conduit

Total Connected Power: 50 amp (DWO) / 30 amp (SWO)

NOTE: Unit includes a 5½-ft flex conduit to be used between the oven and conduit box. Connectors are supplied by the installation electrician.

NOTE: Branch circuit **MUST** be protected with a 50-amp (Double Wall Oven) or 30-amp (Single Wall Oven) over-current protector.

⚠ CAUTION: If there is a high leg in supply voltage, ensure it is not on L2. Having it present on L2 will damage critical 120V oven components.

1.2 SPECIFICATIONS AND INSTALLATION

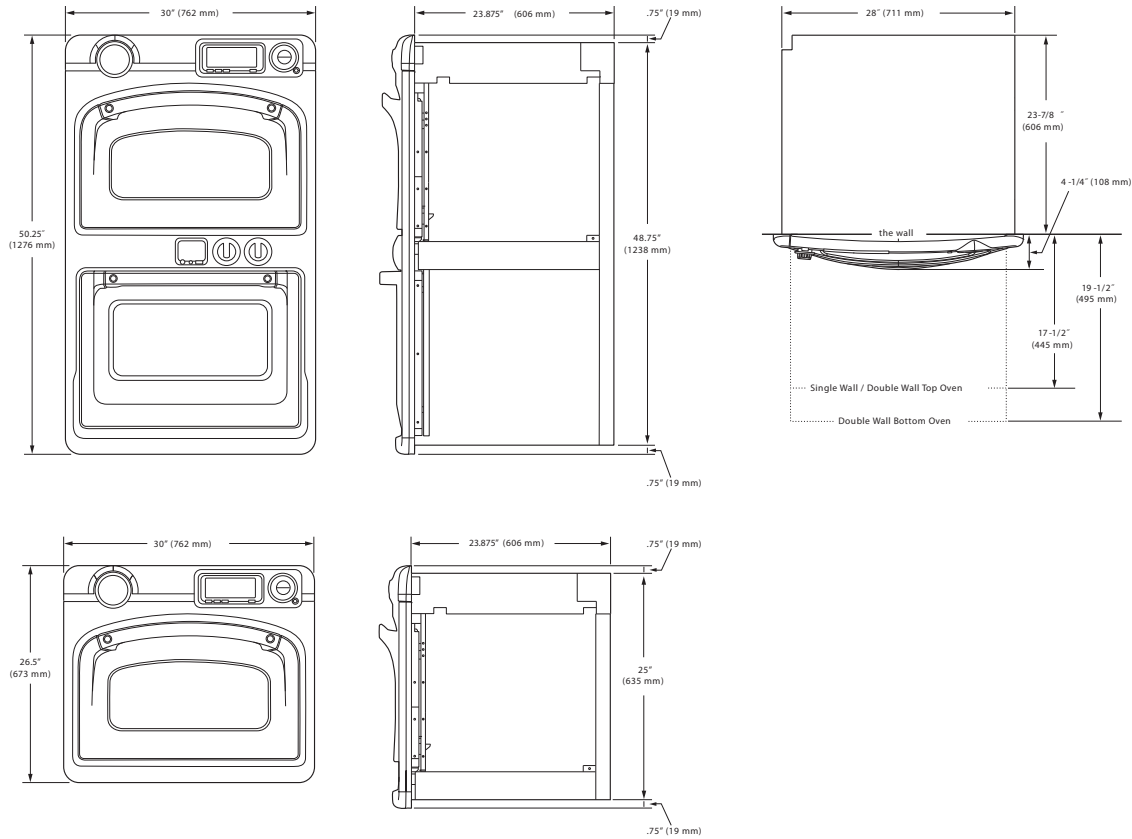

Figure 1.1: Oven Dimensions

Dimensions - Double Wall Oven

Oven Dimensions

Height: 50.25" (1276 mm)

Width: 30" (762 mm)

Depth: 23.875" (606 mm)

Depth from wall (Doors Closed): 4.25" (108 mm)

With Upper Door Open: 17.5" (445 mm)

With Lower Door Open: 19.5" (495 mm)

Weight: 410 lbs (186 kg)

Upper Cook Cavity Dimensions

Height: 12" (305 mm)

Width: 24" (610 mm)

Depth: 15" (381 mm)

Cooking Space: 2.5 ft³ (.07 m³)

Lower Cook Cavity Dimensions

Height: 15.5" (394 mm)

Width: 24" (610 mm)

Depth: 17.5" (445 mm)

Cooking Space: 3.75 ft³ (.106 m³)

Dimensions - Single Wall Oven

Oven Dimensions

Height: 26.5" (673 mm)

Width: 30" (762 mm)

Depth: 23.875" (606 mm)

Depth from wall (Door Closed): 4.25" (108 mm)

Depth from wall (Door Open): 17.5" (445 mm)

Weight: 230 lbs (105 kg)

Cook Cavity Dimensions

Height: 12" (305 mm)

Width: 24" (610 mm)

Depth: 15" (381 mm)

Cooking Space: 2.5 ft³ (.07 m³)

Installation

Cabinets should be cut according to dimensions on pages 1.4 and 1.5. Failure to adhere to the **Rough Wall Opening** specifications may cause corners of the cabinet opening to be exposed. If the oven is being installed near a wall or door, there should be at least .25 in (6.35 mm) space between the wall/door and the sides of the oven trim.

TurboChef recommends using standard 2x4 wood support posts with a minimum of .5 in (12.7 mm) solid base to support the oven. Support posts should be level with the floor line and well secured to the base of the cabinet. Base cabinet support must be able to support the oven's weight – 410 lbs (186 kg) DWO and 230 lbs (105 kg) SWO. TurboChef strongly recommends a solid base as shown in the illustrations on the following page.

Due to the oven frame's overall depth, adhere to the power supply line location shown in Figures 1.2 and 1.3 on page 1.4 to obtain a proper fit in the cabinet. If necessary due to a low or high conduit box, a 2" diameter hole should be drilled where indicated to allow the power cord to reach the power source.

NOTE: DO NOT shorten conduit. Correct conduit before installing oven into cabinet.

The oven utilizes ambient air from the kitchen to assist in keeping the operational components cool. This air is drawn in through the top control panel area through openings in the top access panel and exhausted through an opening at the base of the oven. Please allow a 1-inch minimum clearance above and below these areas.

Should you have any questions or concerns about how the cabinets are built, please contact TurboChef Customer Service 866.447.3783 before installing the oven.

Installation Safety Instructions

Read all installation instructions thoroughly before installing.

⚠ CAUTION: DO NOT lift the oven by the door handle(s). Doing so will require a door-leakage test to be performed (see page 5.4), and could cause the door(s) to come off or misalign, requiring repair and/or replacement.

⚠ CAUTION: The Double Wall Oven weighs 410 lbs (186 kg), and the Single Wall Oven weighs 230 lbs (105 kg). Two or more individuals are required to lift either oven.

⚠ CAUTION: DO NOT remove bottom wood support rails until the oven is lifted into the cabinet.

- Due to the oven's weight, it is sometimes necessary for installers to utilize special handling equipment, such as hand trucks, dollies, etc. Use of such equipment can damage the kitchen floor surfaces. TurboChef recommends that all exposed floor surfaces be protected by applying laminate or plywood sheets, along with protective moving blankets before using such equipment. Failure to do so may result in scarring and damaging the homeowner's floors.
- Installation, electrical connections, circuit breakers, and grounding must comply with local codes.
- Ensure power is disconnected at the breaker throughout the installation process.
- This oven contains breakable components – use extreme caution when lifting and placing it.
- A minimum 1-inch clearance, to allow for proper airflow, is required above the top control panel area and below the base. Failure to maintain this clearance may cause the oven to function improperly.
- **DO NOT push on the outer frame.** Doing so could cause the door(s) to misalign, requiring repair and/or replacement.
- During installation, TurboChef recommends removing the lower door prior to lifting the oven from the front (Double Wall Model only.) **DO NOT remove the top door of the oven during installation or at any other time.** This door should only be removed by an authorized service agent.

1.4 SPECIFICATIONS AND INSTALLATION

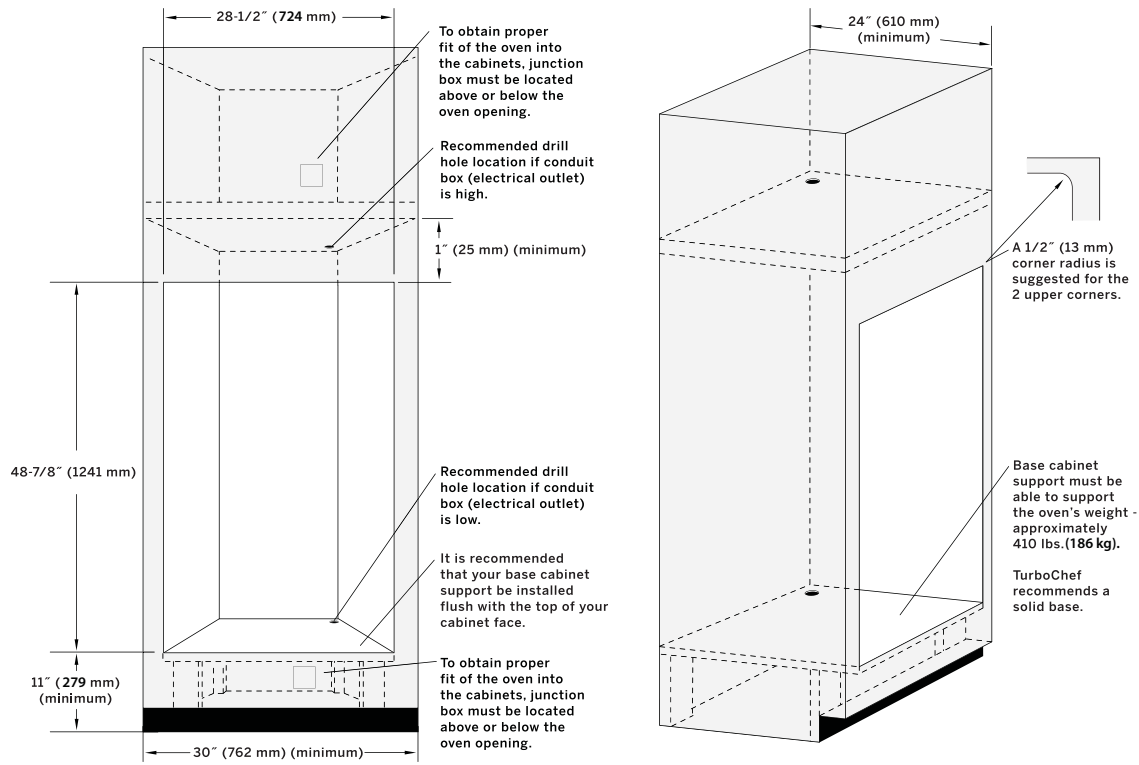

Figure 1.2: Cabinet Dimensions and Specifications, Double Wall Oven

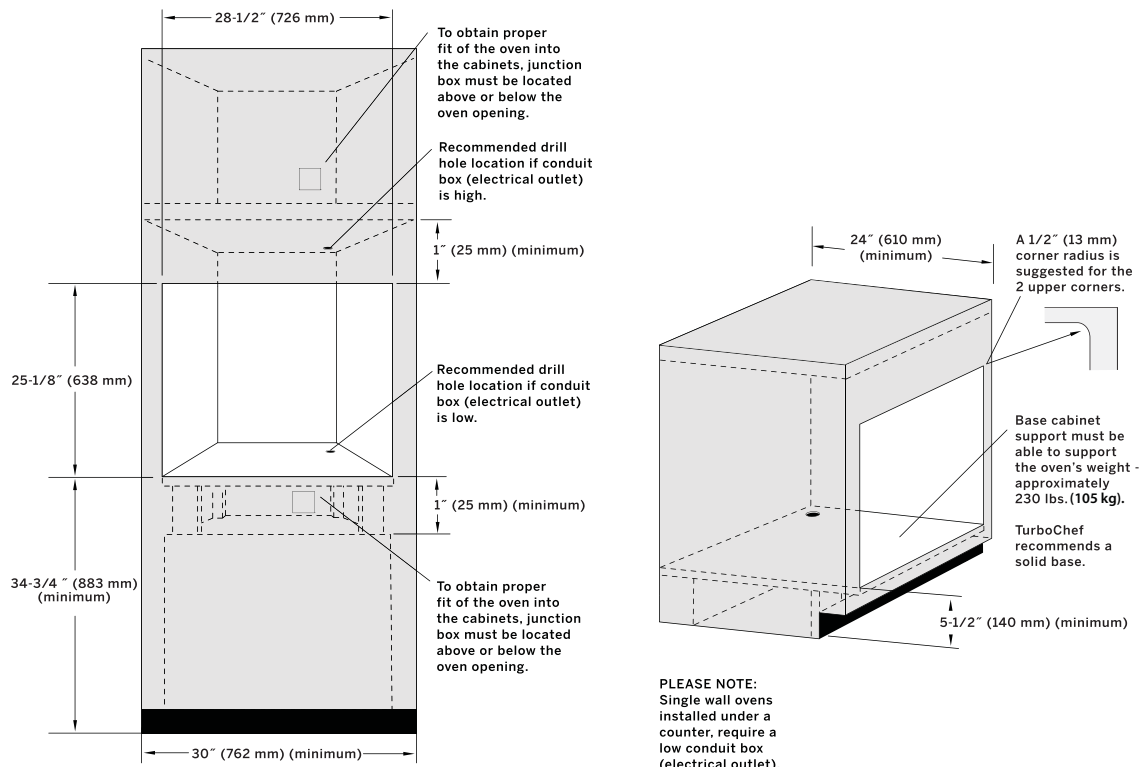
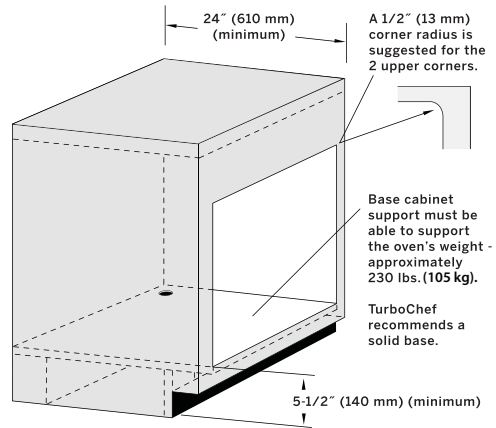

Figure 1.3: Cabinet Dimensions and Specifications, Single Wall Oven (Wall Installation)



PLEASE NOTE:
Single wall ovens installed under a counter, require a low conduit box (electrical outlet).

Figure 1.4: Cabinet Dimensions and Specifications, Single Wall Oven (Under Counter)

Double Wall Oven Cabinet Dimensions

Cabinet

Width (min): 30" (762 mm)

Wood Fascia Thickness (min): $\frac{3}{8}$ " (10 mm)

Rough Wall Opening

Height (min/max): $48\frac{7}{8}$ " (1241 mm)

Width (min/max): $28\frac{1}{2}$ " (726 mm)

Upper Corner Radius (preferred): $\frac{1}{2}$ " (13 mm)

Depth (min): 24" (610 mm)

Cabinet Base Height

Wall Installations (min): 11" (279 mm)

Wall Installations (max): 15" (381 mm)

NOTE: Failure to adhere to the rough wall opening specs may cause corners of the cabinet opening to be exposed.

Single Wall Oven Cabinet Dimensions

Cabinet

Width (min): 30" (762 mm)

Wood Fascia Thickness (min): $\frac{3}{8}$ " (10 mm)

Rough Wall Opening

Height (min/max): $25\frac{1}{8}$ " (638 mm)

Width (min/max): $28\frac{1}{2}$ " (726 mm)

Upper Corner Radius (preferred): $\frac{1}{2}$ " (13 mm)

Depth (min): 24" (610 mm)

Cabinet Base Height

Wall Installations (min): $34\frac{3}{4}$ " (883 mm)

Wall Installations (max): $38\frac{3}{4}$ " (984 mm)

Under Counter Installations (min): $5\frac{1}{2}$ " (139 mm)

NOTE: Failure to adhere to the rough wall opening specifications may cause corners of the cabinet opening to be exposed.

Installing the Oven

⚠ CAUTION: Before installing the oven, verify voltage at the wall receptacle matches the voltage specified on the oven's rating plate (located behind the Speedcook oven door). Each oven is voltage specific and will not function properly if supply voltage is different than intended voltage.

1. Ensure power is disconnected at the breaker.
2. Remove oven from box/crate and place on a level surface.

NOTE: The oven is shipped with two support rails attached to the bottom. These rails allow the oven to sit level and keep the bottom of the frame from being damaged during installation. To properly place the oven into the cabinets, these support rails must be removed.

3. Remove all packing materials.
4. Verify the cabinet is built to the proper specifications.
5. If provided, install the base slide plate (Figure 1.5, below). This plate will make installation and future servicing of the oven easier.

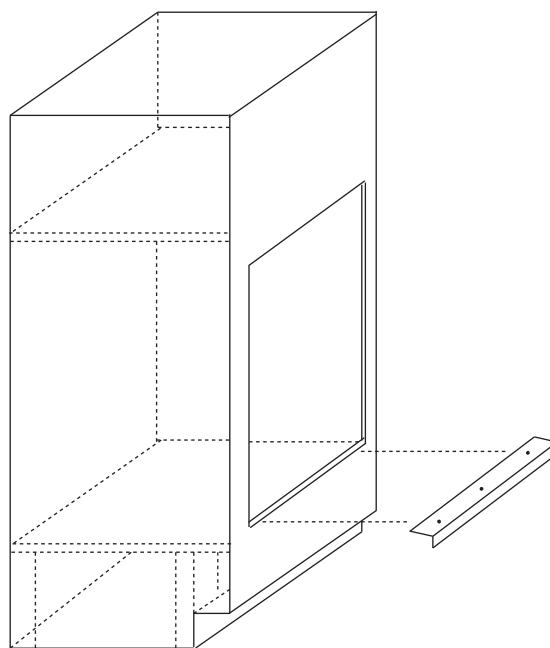

Figure 1.5: Base Slide Plate Installation

1.6 SPECIFICATIONS AND INSTALLATION

NOTE: You may screw or nail the base slide plate in place if required.

NOTE: If the cabinet is not built to the proper specifications, please consult with the contractor, builder, or end user.

6. Place the oven in front of the cabinet, allowing room to access wires.
7. Make the electrical connection. The electrical supply should be a 4-wire single-phase AC. Connect the red, black, white, and green (ground) oven wires to the corresponding colors of the electrical supply wires. Route flex conduit to allow for oven removal for servicing.

NOTE: For branch circuits installed before 1996, a 3-wire hook up may be allowed. See NEC, or qualified electrician for details.

8. Place the oven into the cabinet.

⚠ WARNING: The Double Wall Oven weighs approximately 410 lbs (186 kg), The Single Wall Oven weighs approximately 230 lbs. (105 kg.). Each oven requires two or more individuals to lift it.

⚠ WARNING: DO NOT push on the outer frame. Doing so could cause door(s) to misalign, requiring repair and/or replacement.

When the unit is lifted into the cabinet opening, the installer must remove the support rails one at a time to allow the oven to slide into the opening properly. Remove each support rail by unscrewing the support screw on either side of the rail. Supports should then slide off the oven base.

When sliding the oven into its final position, the installer should continually pull the conduit through the electrical drill hole for it to remain taut and not become twisted or lodged behind the oven.

NOTE: Ovens are built voltage specific. A 208-volt oven will not operate properly if connected to a 240-volt source, and vice versa. Improper voltage supplied to the oven will void the manufacturer's warranty and cause damage to oven components.

9. Reconnect power to the breaker.
10. Secure the oven to the cabinets:
 - a. Open the oven door(s).
 - b. Making sure the oven is fully installed against the front of the cabinet, install two of the supplied screws in the upper cavity, and two in the lower cavity (lower cavity screws only applicable to the Double Wall Oven), through the side trim holes on either side. The screws should engage the inner cabinet and secure the oven in place.
11. Remove all plastic wire ties and packing material from the top and bottom oven cavities/racks (bottom oven cavity only applicable to the DWO oven).
12. Verify the oven is functional and set the clock.
 - a. "Re-Boot" the oven after the initial installation.
 - i. Advance the CookWheel on the top oven to "Bake."
 - ii. Press and hold all four buttons on the display at the same time for two seconds.
 - b. The display should illuminate, the TurboChef logo should appear, and the oven should chime. Once this is verified, return CookWheel to the "Off" position.

NOTE: DO NOT attempt to program any cook programs in the top oven during installation.

- c. Confirm that the oven is set to the proper configuration: Double Wall Oven or Single Wall Oven (see *Oven Configuration* page 4.4).
 - d. Set the clock by pressing the Set Clock Knob (top knob next to the clock). The knob will pop out. Turn the knob left or right to set the correct time. When the time is set, press the knob back in to its original position.
13. Leave all warning decals and instructional labels on the oven for the consumer to view.
 14. Ensure all paper and plastic is removed from the cook cavity. Ensure the consumer is aware of and has access to the provided oven literature and operating instructions.

Section 2

Oven Controls and Cooking - The Speedcook Oven

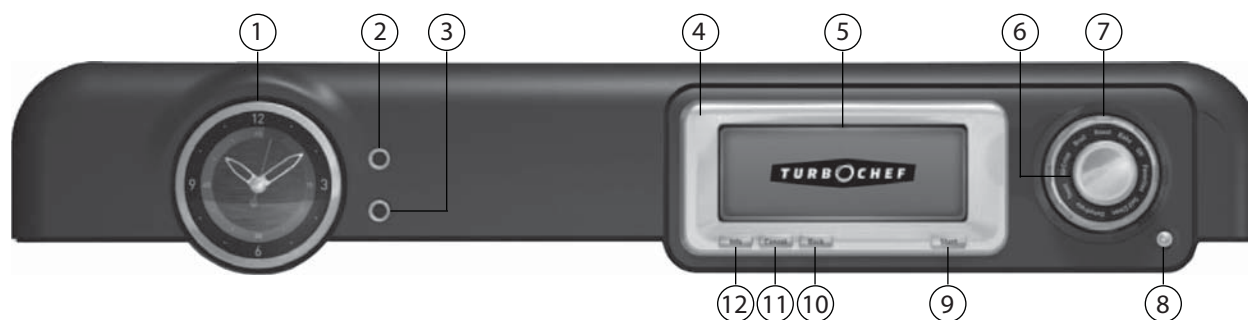

Figure 2.1: Oven Controls

Speedcook Oven Controls

1. Analog Clock and Timer

The clock and timer run with advanced electronic control knobs. To operate, see 2. *Set Clock Knob* and 3. *Set Timer Knob*.

2. Set Clock Knob

To set the time,

1. Press knob to extend.
2. Turn knob to set time.
3. Press knob back in to original position.

3. Set Timer Knob

To set the timer,

1. Press knob to extend.
2. Turn knob to set timer – up to 60 minutes.
3. Press knob back into original position.

NOTE: The timer does not begin counting down until the knob is pressed back in. The oven will chime four times at the end of the timer cycle.

4. Cook Navigator™

Consists of the Display (5), Start Key (9), Back Key (10), Cancel Key (11), and Info Key (12).

5. Display

The display shows information relevant to the current oven operation and/or user options.

6. CookWheel™ (inner knob)

Turn to navigate through the options on the display. Press knob to select an option, begin a preheat cycle, or initiate a cook cycle.

7. CookWheel™ (outer knob)

Turn to select a Speedcook mode, Self-Clean, or to turn the oven off. Modes include: Air-Crisp, Bake, Broil, Favorites, Dehydrate, Roast, and Toast.

8. Oven Light Switch

Press to illuminate the top cook cavity.

9. Start Key

Press to select an option, begin a preheat cycle, or initiate a cook cycle.

NOTE: Pressing the “Start” key performs the same function as pressing in the inner CookWheel knob.

10. Back Key

Press to return to the previous screen.

11. Cancel Key

Press to terminate a cook cycle or to return to the main screen.

12. Info Key

Press to display information on the Oven Setup (sound, units & measurements, display, and software updates), Help Topics, and Oven Tips.

NOTE: When the oven is in the middle of a cook cycle, you will not be able to access the Info screen.

Cook Modes

The Speedcook oven features seven modes that enable the user to cook a wide variety of foods.

- Air-Crisp
- Bake
- Broil
- Dehydrate
- Favorites
- Roast
- Toast

To access Air-Crisp, Bake, Broil, Dehydrate, Favorites, Roast, or Toast cook modes, turn the CookWheel to the desired cook mode.

NOTE: Unlike traditional ovens or the lower double wall oven, Speedcook oven cooking parameters will vary significantly on a cook-by-cook basis. For troubleshooting cooking problems, see section 6 in this manual. For information on component measurements and testing, see section 5.

The table below details heater element activity.

Mode	Convection Fan	208 VAC Value	240 VAC Value
Preheat	Off	30.8 ± 3.0	28.8 ± 3.0
All Modes	Off	20.5 ± 2.0	19.2 ± 2.0

Air-Crisp

Think of Air-Crisp as air-frying. This mode is great for foods that traditionally taste best when fried – like french fries – as well as items containing any sort of breading or stuffing that should toast and brown in the cooking process – like stuffed mushrooms.

In this mode, high temperature air moves through the cook cavity at varying speeds to brown and crisp the food product. Food comes out with a nice caramelization and is lower in fat content than if it had been deep fried. Metal sheet pans work well in this mode.

Bake

Traditionally, baking is cooking with dry heat. Hot air from the top and bottom of the oven envelopes the food in a radiant dry heat, perhaps with a little moisture from the food, which circulates as a vapor in the oven.

In the TurboChef® Speedcook Oven, the traditional explanation of baking remains the same. However, the hot air is moved through the cook cavity at higher speeds than in a traditional oven. This rapid movement of air decreases cook times while ensuring foods bake evenly and retain more moisture. When in the Bake mode, keep in mind that metal cookware will provide more bottom browning while items in glass cookware will cook a little faster. Bake pizzas on a pizza pan or place them directly on the oven rack. Some casseroles may need to be covered with parchment paper to prevent over-browning.

Broil

Broiling directly exposes food to radiant heat (as over a fire or on top of a grill). The heat is direct and intense, and it differs from baking or roasting in that only one side of the food is exposed to the heat source. Generally, broiled foods are quick cooking, inherently tender, relatively lean, and not too thick.

The Broil mode on the TurboChef Speedcook Oven will yield the same or superior results as broiling in any traditional oven. The only real difference is that your food cooks faster due to the hot air moving through the cook cavity at increased speeds.

Cast iron grill pans, metal sheet pans, and metal broiling pans all work well in this mode.

Dehydrate

Considered the original form of preservation, dehydrating food removes the product's natural moisture by slowly drying it with a low heat. Manually, food can be dehydrated by placing thin slices on racks and allowing them to dry assisted only by sun or air. To shorten the dehydrating process, the TurboChef oven utilizes low temperature air moving at higher speeds.

This mode is ideal for products like banana chips and other dried fruits, as well as dried meats, like beef jerky. Sheet pans, TurboChef teflon screens, and pizza pans (with or without holes) are all recommended for use with this mode.

Favorites

The Favorites mode is a tool that allows the user to store and easily recall up to 9,999 cook settings for the user's favorite recipes. This mode truly allows you

to cook any recipe quickly and easily – regardless of whether it is a perfect match to one of the pre-programmed settings or not. In addition to any settings that the user saves, the settings for the last ten cooks are always saved in this mode. The Favorites mode gives the user access to Convection Bake, Defrost, and Microwave functions. To learn more about the Favorites mode, see below.

Roast

Traditionally, roasting implies cooking food with an open flame, as on a spit in front of a fire.

Roasting and baking in an oven are essentially the same thing, but roasting is mostly used for meats and vegetables. In the top oven, a combination of low and high speed air is used to brown the outside of food while retaining moisture inside.

Roasting pans (without lids), glass casserole dishes (with or without lids), and sheet pans all work well with this mode. Shallow pans will allow food to brown more. An uncovered pan without liquids will help keep the heat dry and allow foods to brown and crisp. Setting meats and poultry directly on a rack in a pan keeps them from steaming in their own juices.

Toast

Toasting browns and crisps foods like bread, bagels, and tortillas. Using high heat and high speed air, the Toast Mode can enhance flavor and melt cheese.

For best results, place food directly on the oven rack. For products that may run over, like filled pastries, use a metal sheet pan.

Favorites Cooking

The Favorites mode allows the user to store and quickly access the cook settings for their favorite recipes and food items and gives them access to the convection bake, defrost, and microwave modes (for information on how to access convection bake, defrost, and microwave functions, see page 2.4).

Cooking in the Favorites mode generally follows the *Basic Cooking* process on page 2.5; however, users must choose between cooking a recently prepared dish, cooking a “Favorites” dish, or using the convection bake, defrost, or microwave functions.

NOTE: Convection bake, defrost, and microwave cook cycles cannot be saved to Favorites and will not appear in “View Last Cooked (10).”

This section contains information about the following:

- Cooking a Recently Prepared Dish
- Cooking a “Favorite” Dish
- Using the Convection Bake Mode
- Using the Defrost Mode
- Using the Microwave Mode

NOTE: If the oven does not contain some of these options, verify it has received the most recent software upgrade. See page 4.3 for details.

NOTE: If for some reason the SD card must be replaced, you must back up your Favorites to retain them. See page 4.3 for more details.

Cooking a Recently Prepared Dish

The Speedcook oven automatically saves a record of the user’s last 10 cooks, including any adjustments made to the selected preprogrammed setting, giving the user quick access to their most recently-used cook settings.

To cook a recently-prepared dish,

1. Turn the CookWheel to “Favorites.”
2. Select “View Last Cooked (10).”
3. Select the dish to be cooked.
4. Select “Cook” and press start or the inner CookWheel knob.
5. Follow the *Basic Cooking* steps (page 2.5), beginning with MODE 3.

Cooking a “Favorite” Dish

The Favorites mode allows the user to store and quickly access the cook settings for your favorite recipes and food items. To save a dish to Favorites, see page 2.9.

To cook a “Favorite” dish,

1. Turn the CookWheel to “Favorites.”
2. Select the dish to be cooked.
3. Select “Cook” and press start or the inner CookWheel knob.
4. Follow the Basic Cooking steps from MODE 3.

Using the Convection Bake Function

The Favorites mode gives the user access to the convection bake function. When set to convection bake, the Speedcook oven operates as a standard convection oven with the fans running at a low speed. The Speedcook oven's convection bake function creates the same cooking environment as setting the bottom oven in the Double Wall Model to the convection bake mode.

To use the convection bake function,

1. Turn the CookWheel to "Favorites."
2. Select "Convection Bake" and press start or the inner CookWheel knob.
3. Set the desired time.
4. Set the desired temperature.
5. Press start to begin preheating.
6. When preheating is complete (the oven will chime), place food in the oven and press start.

 **WARNING:** Inside of oven and oven door are hot! Use extreme caution.

NOTE: Food placed in the oven will begin cooking regardless of whether start is pressed or not. However, when start is pressed, the timer begins counting down.

7. When cooking is complete (the oven will chime), remove the food from the oven.

 **WARNING:** Dish and inside of oven/oven door are hot! Use extreme caution.

NOTE: If additional time is needed, the user can add time to the timer by pressing start.

8. When done cooking, turn the oven off by turning the CookWheel to Off.

Using the Defrost Function

The Favorites mode gives the user access to the defrost function. The defrost function should be used to aid in the thawing of foods, especially frozen meats and casseroles.

To use the defrost function,

1. Turn the CookWheel to "Favorites."
2. Select "Defrost" and press start or the inner CookWheel knob.

3. Set the desired time.
4. Set the desired power level.

NOTE: For defrost applications, the power level automatically defaults to 10% (recommended for most foods).

5. Place food item in the oven and press start.
6. When defrosting is complete (the oven will chime), remove the food from the oven.

 **WARNING:** Dish and inside of oven/oven door are hot! Use extreme caution.

NOTE: If additional time is needed, the user can add time to the timer by pressing start.

7. When done defrosting, turn the oven off by turning the CookWheel to Off.

Using the Microwave Function

The Favorites mode gives the user access to the microwave function. When the microwave function is selected, the Speedcook oven operates as a standard microwave oven. This function should be used primarily for applications such as popping popcorn or boiling water.

To use the microwave function,

1. Turn the CookWheel to "Favorites."
2. Select "Microwave" and press start or the inner CookWheel knob.
3. Set the desired time.
4. Set the desired power level.
5. Place food item in the oven and press start.
6. When cooking is complete (the oven will chime), remove the food from the oven.

 **WARNING:** Dish and inside of oven/oven door are hot! Use extreme caution.

NOTE: If additional time is needed, the user can add time to the timer by pressing start.

7. When done cooking, turn the oven off by turning the CookWheel to Off.

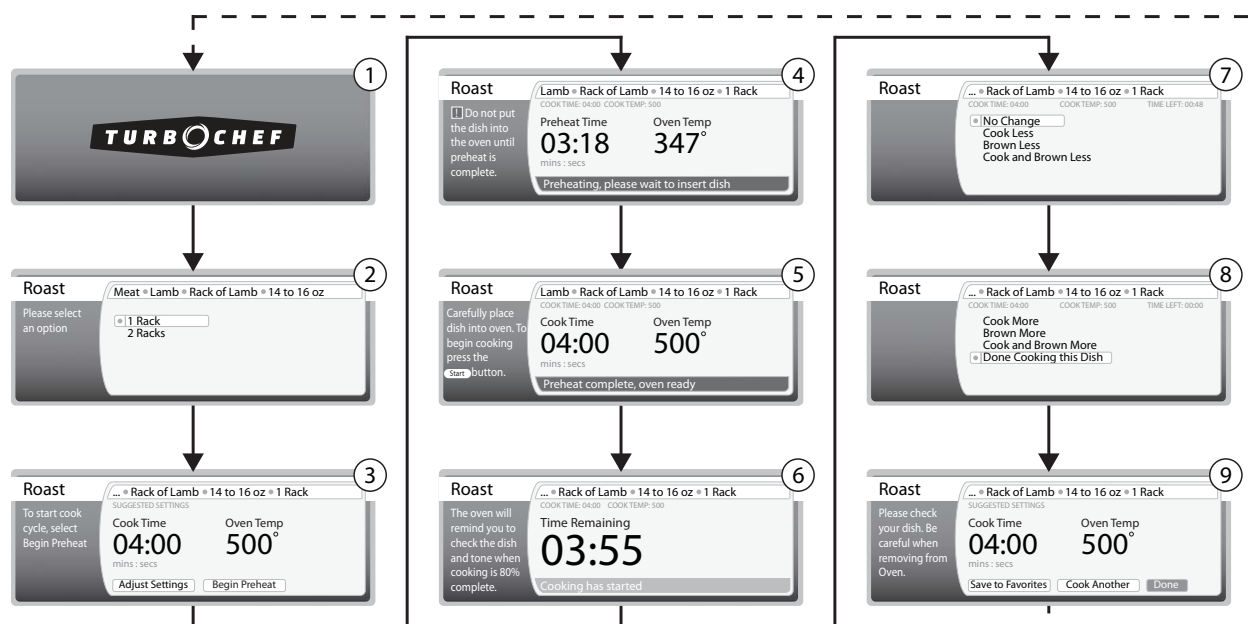

Figure 2.2: Standard Operation Modes

Basic Cooking

Figure 2.2

This section explains how to cook a food item by describing the “standard operation” modes through which the Speedcook oven progresses.

The oven is preprogrammed with recipe settings at the time of manufacture and is ready to operate after installation.

NOTE: Modes are not always sequential, as shown in Figure 2.2, above.

- MODE 1: Oven Off
- MODE 2: Select a Food Item
- MODE 3: Confirm Settings
- MODE 4: Preheat
- MODE 5: Ready to Cook
- MODE 6: Cooking
- MODE 7: 80% Complete
- MODE 8: 100% Complete
- MODE 9: Remove Food from Oven

Mode 1: Oven Off

Mode during which the oven is turned off. To begin cooking, the user must first select, using the CookWheel, one of the seven speedcook modes (Air-Crisp, Bake, Broil, Dehydrate, Favorites, Roast, or Toast).

Happens When...

- The user turns the CookWheel to the “Off” position at any time.

Goes To...

- MODE 2 when the user turns the CookWheel to Air-Crisp, Bake, Broil, Dehydrate, Roast, or Toast.
- Favorites when the user turns the CookWheel to Favorites (for more information on Favorites, see page 2.3).

Mode 2: Select a Food Item

Mode during which the user specifies which dish to cook. Use the inner CookWheel knob to select the item and item specifications. To make a selection, scroll to the desired option and press the inner CookWheel knob or start key.

Happens When...

- The user turns the CookWheel to Air-Crisp, Bake, Broil, Dehydrate, Roast, or Toast from MODE 1.
- The user presses cancel from MODE 7.
- The user selects "Done" from MODE 9.

Goes To...

- MODE 3 when the user selects the desired food item and item specifications.

Mode 3: Confirm Settings

Mode during which the user either confirms the suggested cook settings, or chooses to adjust the cook settings (for more information on adjusting cook settings, see page 2.8).

Happens When...

- When the user selects the desired food item and item specifications from MODE 2.

Goes To...

- MODE 4 when the user selects the "Begin Preheat" option.
- Adjust Settings when the user selects the "Adjust Settings" option (for more information on adjusting cook settings, see page 2.8).

Mode 4: Preheat

Mode during which the oven preheats to the set temperature. The oven automatically begins counting down the remaining preheat time and displays the current temperature. Preheating will take approximately 8-14 minutes.

Happens When...

- The user selects the "Begin Preheat" option from MODE 3.

Goes To...

- MODE 5 when the oven chimes, indicating that the preheat cycle is complete.

NOTE: If the door is opened while the oven is preheating, the oven displays the message "The oven door is open. You must close the oven door before continuing." If applicable, the air will power down to 30%.

Mode 5: Ready to Cook

Mode during which the oven is ready to cook a food item. Place the food into the oven at this time. Press start to begin the cook cycle.

 **WARNING:** Inside of oven and oven door are hot! Use extreme caution.

Happens When...

- The oven has reached the set temperature. The oven will chime, indicating it is ready to cook.
- The user selects "Cook Another" from MODE 9.

Goes To...

- MODE 6 when the user presses start.

Mode 6: Cooking

Mode during which the oven cooks a food item.

NOTE: To immediately terminate cooking, turn the CookWheel to off.

NOTE: The oven door must be completely closed before the oven will initiate a cook cycle. If the door is opened while the oven is cooking, the oven displays the message "The oven door is open. You must close the oven door before continuing." If applicable, the microwave system shuts off and the air will power down to 30%.

Happens When...

- The user presses start from MODE 5.

Goes To...

- MODE 7 when the cook cycle is 80% complete (if the cook cycle exceeds 2:30).
- MODE 8 if the cook cycle is less than 2:30.

Mode 7: 80% Complete

Mode during which the cook cycle is 80% complete. When the cook cycle is 80% complete, a chime sounds, the cook cycle pauses, and the user has the option to check the food and, if desired, adjust the cook settings. At this point in the cook cycle, the user can choose one of the following four options:

- No Change: Select if dish is cooking to expectations.
- Cook Less: Select if product is overcooking or internal temperature is too high.

- Brown Less: Select if the outside of the dish is browning faster than desired.
- Cook and Brown Less: Select if dish is cooking and browning more than expected, but requires additional cooking time.

If after 30 seconds the oven has not been addressed (door opened or inner CookWheel knob pressed), the oven will complete the cook cycle according to the original settings.

NOTE: For food items with a cook time of 2:30 or less, the cook cycle does not pause at the 80% complete mark.

NOTE: If the food item is done at this time, remove it from the oven and press cancel to end the cook cycle. If you end the cook cycle at this point, the cook cycle will not be recorded in “View Last Cooked (10)” (for more information on “View Last Cooked (10), see page 2.3).

Happens When...

- The cook cycle is 80% complete.

Goes To...

- MODE 2 if the user presses cancel.
- MODE 8 after 30 seconds of inactivity, or if the user selects “No Change,” “Cook Less,” “Brown Less,” or “Cook and Brown Less.”

Mode 8: 100% Complete

Mode during which the cook cycle is 100% complete. At the end of a cook cycle, a chime sounds notifying the user that the food item is done. The user has the option to add additional cook time, if desired. At this point in the cook cycle, the user can choose one of the following four options:

- Cook More: Select if the outside meets expectations, but the inside needs to cook longer.
- Brown More: Select if the inside meets expectations, but outside needs to cook longer.
- Cook and Brown More: Select if both the inside and outside need to cook longer.
- Done Cooking this Dish: Select if no adjustments are needed.

NOTE: If the user selects “Cook More,” “Brown More,” or “Cook and Brown More,” the user can add up to 30% of the original cook time in 5-second increments. This can be repeated as many times as necessary.

This option is available for 3 minutes. After 3 minutes of inactivity, the oven assumes the item is done.

Happens When...

- The cook cycle is 100% complete.

Goes To...

- MODE 9 if the user selects “Done Cooking this Dish.”
- MODE 6 if the user selects one of the “cook/ brown more” options.

Mode 9: Remove Food from Oven

Mode during which cooking is complete, and the food item is ready to be removed from the oven. The user has the option to “Save to Favorites,” “Cook Another,” or “Done.”

 **WARNING:** Dish and inside of oven/oven door are hot! Use extreme caution.

NOTE: The display will not change until “Save to Favorites,” “Cook Another,” or “Done” is selected or until the oven is turned off.

Happens When...

- The user selects “Done Cooking this Dish” from MODE 8.

Goes To...

- MODE 1 if the user turns the CookWheel to off.
- MODE 2 if the user selects “Done.”
- MODE 5 if the user selects “Cook Another.”
- Save to Favorites (see page 2.9), if the user selects “Save to Favorites.”

NOTE: If the user selects “Cook Another,” the next cook cycle will use the same settings as the previous cook cycle. This includes any adjustments made at any point during the previous cook cycle.

Adjusting a Recipe's Cook Time

Cook times may be altered up to 25% in either direction of the preprogrammed time. Be aware that preprogrammed cook times can vary significantly from traditional settings.

To adjust the cook time,

1. From MODE 3, select "Adjust Settings" (Figure 2.3).
2. Use the inner CookWheel knob to scroll to the cook time and press the knob to select it (Figure 2.4).
3. Turn the inner CookWheel knob to adjust the cook time in 5-second increments. The original cook time cannot be altered more than 25% in either direction (Figure 2.5).
4. Press the inner CookWheel knob to confirm the new cook time.
5. Scroll to and select "Begin Preheat."

Adjusting a Cook Temperature

Temperatures may be altered up to 25°F (14°C) in either direction. Note that preprogrammed temperatures can vary significantly from traditional settings.

To adjust a cook temperature,

1. From MODE 3, select "Adjust Settings" (Figure 2.3).
2. Use the inner CookWheel knob to scroll to "Oven Temp," press knob to select (Figure 2.6).
3. Turn the inner CookWheel knob to adjust the temperature in 5°F (2°C) increments. The temperature cannot be altered more than 25°F (14°C) in either direction (Figure 2.7).

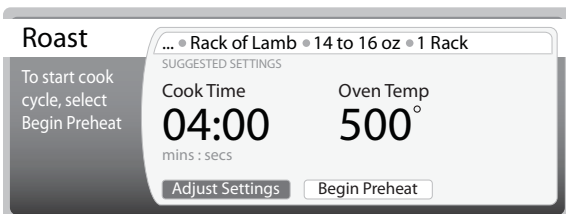

Figure 2.3: Adjusting Recipe Settings

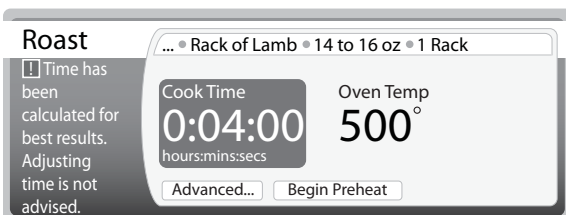

Figure 2.4: Selecting Cook Time

4. Press the inner CookWheel knob to confirm the new temperature.
5. Scroll to and select "Begin Preheat."

The Advanced Cook Mode

In the advanced cook mode (Figures 2.8 and 2.9), the user can adjust the airflow and microwave power levels of a preprogrammed setting. In addition to customizing an existing setting, making adjustments in the advanced cook mode enables the user to develop new settings from pre-existing ones. A high level of familiarity with the oven is suggested before attempting to make changes in this mode.

Each programmed setting is divided across four intervals, each of which has four associated settings:

- Time: The length (run time) of an interval. Time settings are not adjustable - only the total cook time can be adjusted (see adjacent).
- Upper Air: Controls speed of the air coming from the top of the oven. Adjust in 10% increments from 0-100%.
- Lower Air: Controls speed of the air coming from the bottom of the oven. Adjust in 10% increments from 0-100%.
- Microwave: Controls the amount of microwave power being used. Adjust in 10% increments from 0-100%.

Use the inner CookWheel knob to scroll to and select the desired setting(s).

To use the Advanced Cook Mode,

1. From MODE 3, select "Adjust Settings" (Figure 2.3).

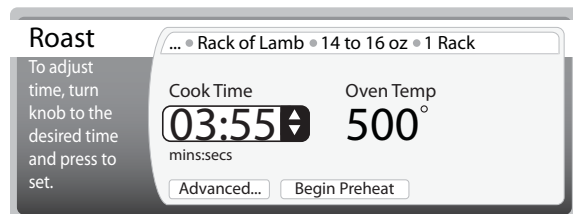

Figure 2.5: Adjusting Cook Time

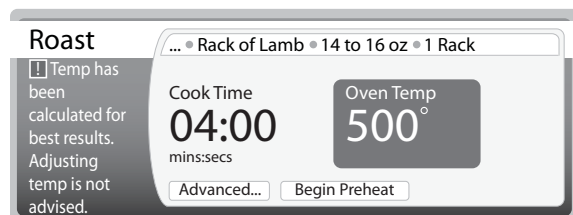

Figure 2.6: Selecting Oven Temp

- Use the inner CookWheel knob to scroll to “Advanced...” and press the knob to select it (Figure 2.8).
- Select the setting to be adjusted and make the desired changes (Figure 2.9).
- Press the inner CookWheel knob to confirm the new settings.
- Select “Done” to confirm changes or “Original Settings” to cancel changes (Figure 2.9).

Saving to Favorites

By allowing the user to store up to 9,999 cook settings, the Favorites mode allows the user to cook anything quickly and easily. The user can create the perfect cook cycle for any product by using a pre-programmed setting and making adjustments at the 80% and 100% complete points. Once the settings are perfected, saving to favorites enables the user to store and easily recall the perfect setting for the next time they cook that recipe.

The user can save to favorites when:

- Cooking is paused via oven door being open
- A cook cycle is 80% or 100% complete
- Selecting a recently-cooked dish from View Last Cooked (10).

To save a dish to favorites,

- From any of the above listed conditions, choose Save to Favorites.

NOTE: If you do not wish to rename the item being saved, skip to step 3.

- To rename a dish:

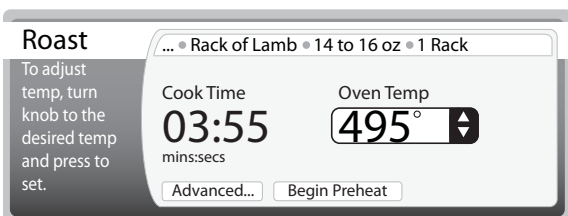

Figure 2.7: Adjusting Oven Temp

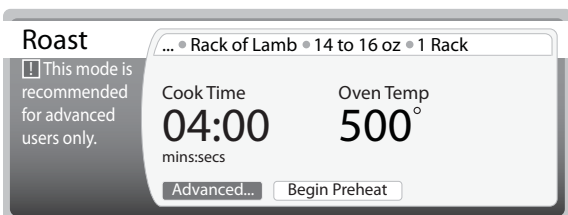

Figure 2.8: Selecting Advanced

- Turn the inner CookWheel knob to advance the cursor to the word you wish to edit or delete, or to select the space between words where you want to add text.
- Press the knob to select the word or space between words.
- To add text:
 - Use the inner CookWheel knob to scroll left and right to select letters (A-Z), numbers (0-9), or punctuation marks.
 - Press the inner CookWheel knob to confirm a character. The cursor will move to the next space.
 - Press the back key to return to a previous character.
 - Predictive matches appear beneath the text being added. Use the inner cook-wheel knob to scroll to and select a match (if applicable).
 - When a word is complete, press the inner CookWheel knob after the final character is confirmed.
- To change or delete text:
 - Use the inner CookWheel knob to highlight the word to be changed or deleted, and press the knob to select the word.
 - A drop-down menu will appear with “change” and “delete” as selectable options (Figure 2.10).
 - If “change” is selected, follow the above instructions for adding text.

NOTE: When re-saving an existing Favorites recipe, previous settings will be replaced with those from the current cook cycle, including any name change.

- Scroll to and select “Done.”

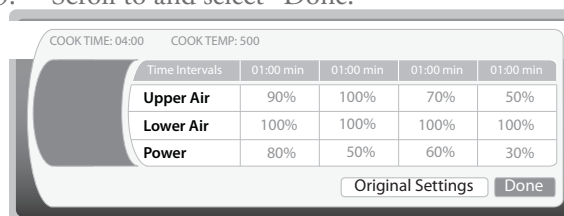

Figure 2.9: Advanced Cook Mode

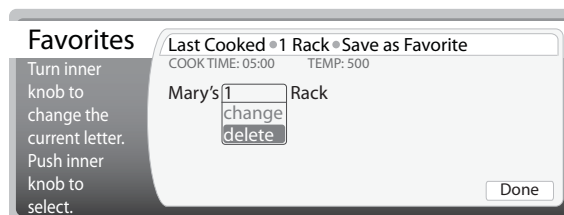

Figure 2.10: Changing or Deleting a Name

Renaming a Dish (in Favorites)

At any time - and as often as the user likes - the user may rename any of the cook settings saved in Favorites.

To change the name of a setting stored in Favorites,

1. Turn the CookWheel to Favorites.
2. Select the dish/cook setting to be renamed.
3. Use the inner CookWheel knob to select “Rename” (Figure 2.11).
4. Rename the selected item (see step 2 of “Saving to Favorites, page 2.9).
5. Select Done.

Deleting a Dish (from Favorites)

Favorite settings that are no longer used or that the user wishes to delete may be removed from the Favorites mode.

To delete a dish from favorites,

1. Turn the CookWheel to Favorites.
2. Select the dish/cook setting to be deleted.
3. Use the inner CookWheel knob to select Delete (Figure 2.11).

NOTE: When Delete is selected, the item/setting is automatically deleted and the oven returns to the initial Favorites screen, which lists all stored Favorite settings in alphabetical order.

Reheat Setting

Use the reheat setting to reheat leftovers. The intended serving size is food for one individual, or a “plate” of food.

1. Turn the CookWheel to Bake.
2. Scroll to Refrigerated Foods, Reheat.
3. Press the Start button to begin reheating.

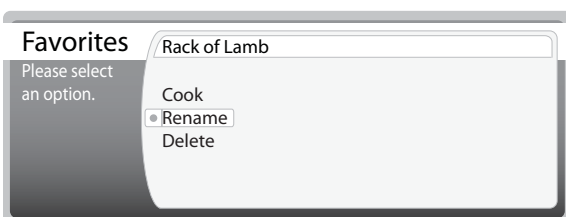

Figure 2.11: Rename a Dish (in Favorites)

Self-Clean Mode - Speedcook Oven

The Speedcook oven is self-cleaning. Using heat up to 900°F (482°C), the oven will self-clean the inside of the cook cavity in approximately 4.5 hours.

NOTE: For the Double Wall Oven, while one oven is in self-clean mode the other will not be functional. Additionally, the top and bottom ovens cannot be self-cleaned at the same time.

NOTE: The oven door will not unlock until the oven cavity temperature recedes below 500°F (260°C).

To initiate a self-clean (Figure 2.12),

1. Ensure the cook cavity is empty and remove the oven rack.

NOTE: Failure to remove the oven rack will cause the rack to discolor.

2. Turn the CookWheel to Self-Clean.
3. Press the Start button.
4. If terminating a self-clean is required, turn the outer CookWheel knob to Off.

During the self-clean cycle, the oven door is locked and oven surfaces can become very hot. When the cleaning cycle is complete and the oven has returned to a safe temperature, the screen displays a message and the oven sounds a tone and powers down.

⚠ WARNING: The oven is extremely hot during self-clean. **DO NOT** touch or attempt to use until self-clean is complete.

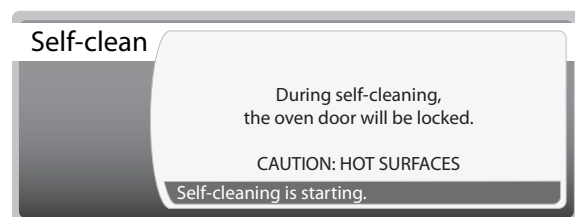

Figure 2.12: Self Clean

Section 3

Oven Controls and Cooking -

Lower Oven (Double Wall Oven Only)

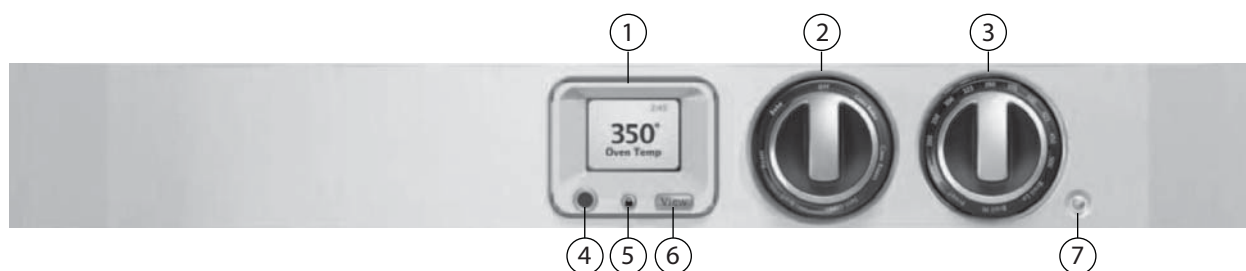

Figure 3.1: Lower Oven Controls (Double Wall Oven models only)

Lower Oven Controls

These controls are only applicable to Double Wall Oven models.

1. Display Screen

Displays the oven and meat probe temperature, as well as the timer information.

2. Oven Mode Dial

Turn to choose the cook mode. For a list of cook modes, see page 3.2.

3. Temperature Dial

Turn the dial to set the oven temperature or to select Broil Low, Broil High, Proof, or Warm.

4. Set Timer Knob

Use to set the timer:

1. Press knob to extend.
2. Turn knob to set timer.
3. Press knob back in to original position.

The timer does not begin counting down until the knob is pressed back in. The oven will chime four times at the end of the timer cycle.

5. Lock Key

When the door is locked, a graphical lock appears on the screen. Hold for 3 seconds to engage/disengage the door lock. Allow 5-10 seconds for lock/unlock to engage.

NOTE: To engage the Sabbath Mode, simultaneously press the “Lock” and “View” keys for 3 seconds. See page 3.3 for details.

6. View Key

Press to toggle between the oven temperature, meat probe temperature, and timer information being displayed in the primary screen position.

7. Oven Light Switch

Press to illuminate the bottom cook cavity.

Cook Modes

The bottom oven (double wall only) is both a conventional and convection oven that provides uniform cooking throughout. The bottom oven features five cook modes.

- Bake
- Broil
- Convection Bake
- Convection Roast
- Roast

The table below details heater element activity within each mode.

Mode	Convection Fan	208 VAC Value	240 VAC Value
Bake	Off	22.3 ± 2.0	19.8 ± 2.0
Broil (High)	Off	14.7 ± 2.0	13.3 ± 2.0
Broil (Low)	Off	14.7 ± 2.0	13.3 ± 2.0
Convection Bake	On	20.3 ± 2.0	17.5 ± 2.0
Convection Roast	On	12.7 ± 2.0	11.0 ± 2.0
Roast	Off	18.0 ± 2.0	15.5 ± 2.0

Bake

Traditionally, baking is to cook with dry heat. Hot air from the top and bottom of the oven envelopes the food in a radiant dry heat, perhaps with a little moisture from the food, which circulates as a vapor in the oven.

In the bottom oven of the double wall oven, unlike most traditional ovens, the bottom heating element is concealed beneath the cook cavity. This feature allows for a bigger cook cavity, easier cleaning, and more uniform heating.

Broil

Broiling directly exposes food to radiant heat (as over a fire or on top of a grill). The heat is direct and intense, and it differs from baking or roasting in that only the top side of the food is exposed to the heat source.

Generally, you broil foods that are quick cooking, inherently tender, relatively lean, and not too thick.

Convection Bake

Convection Bake uses the same heating elements as Bake with the addition of a convection fan and heater in the back of the cook cavity. This fan and heater help heat and circulate the air evenly throughout the chamber to produce superior browning and crisping.

Any food cooked under the Bake mode can also be prepared using Convection Bake and vice versa. Items cooked under Convection Bake will cook about 33% faster than when cooked under Bake.

Convection Roast

Convection Roast uses the same heating elements as Roast. However, unlike Roast, Convection Roast utilizes the convection fan and heater in the back of the oven to help heat and circulate the air throughout the cook cavity.

Any item cooked under Roast can be prepared using Convection Roast and vice versa. The one difference is that Convection Roast uses additional heating elements, causing it to cook about 33% faster.

Roast

Roasting in an oven is essentially the same as baking, but roasting is used mostly for meats and vegetables. Hot air from the top and bottom of the oven is used to brown the outside of food while retaining moisture inside.

In the bottom oven of the Double Wall model, the two top heating elements provide better control and optimized broiling and roasting.

Warm Setting

The warm setting uses heat from the top and bottom of the oven to keep the cook cavity at 145°F (63°C), the perfect holding temperature for food.

Proof Setting

The Proof setting uses heat from the top and bottom of the oven to keep the cook cavity at 90-105°F (32-41°C), the perfect temperature for yeast dough to rise. Some doughs may require moisture to proof correctly. If moisture is needed, place a sheet pan of water under the lower rack.

Basic Cooking

The bottom oven, when used in combination with the top oven, offers the user an expanded capacity.

⚠ WARNING: Due to the concealed heating element in the bottom oven, make sure to not cover or line the bottom of the oven with foil.

To operate the lower oven,

1. Set the oven mode dial to one of the following: Convection Bake, Convection Roast, Broil, Roast, or Bake.
2. Set the oven temperature dial.
 - Along with the various temperature settings, the user could also choose Warm or Proof.
 - The oven's current temperature is displayed as the primary information on the screen.
3. When the oven finishes preheating (Figure 3.2), insert the dish.

⚠ WARNING: Inside of oven and oven door are hot! Use extreme caution.

4. Set the timer (if desired). See page 3.1 for instructions on how to set the timer.

NOTE: When the timer is set, the remaining cook time is displayed as the primary information and the oven temperature as the secondary (Figure 3.3). Press the View key to toggle which information is displayed as primary and secondary (Figure 3.4).

NOTE: When the meat probe is in use, the probe temperature is displayed while the dish is cooking. To toggle between the information displayed in the primary, secondary, and tertiary positions on the screen (Figure 3.5), press the View key.

5. When food has finished cooking, warming, or proofing, carefully remove it from the oven.

⚠ WARNING: Dish and inside of oven/oven door are hot! Use extreme caution.

6. Turn the oven mode dial to the Off position.

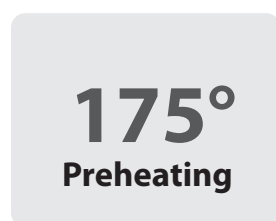

Figure 3.2: Preheating

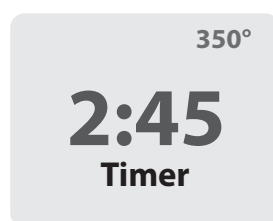

Figure 3.3: Timer Primary

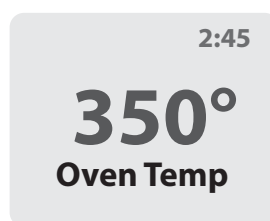

Figure 3.4: Oven Temp Primary

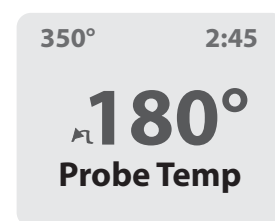

Figure 3.5: Probe Temp Primary

The Sabbath Mode

The Sabbath Mode, available for religious faiths with “no work” requirements on the sabbath, cooks food over a 72 hour period. The Sabbath Mode is Star-K certified.

To use the Sabbath Mode,

1. Press the oven light switch to turn the oven light on.
 - By turning the oven light on via the switch, the light stays on for the duration of the time the oven is in the Sabbath Mode. If the oven light is not turned on, the oven light will turn on and off when the door is opened and closed.
2. Set the oven mode dial and temperature dial as if cooking normally.
3. Simultaneously press the Lock and View keys for 3 seconds. The display will say “Oven display is off when Sabbath Mode is engaged.” This message is displayed for 10 seconds. The display then goes black and remains black as long as the oven is in the Sabbath Mode.
 - In the Sabbath Mode, the oven's display will appear black, however the oven is still active. At any time while the oven is in the Sabbath Mode, the oven's temperature can be adjusted by turning the temperature dial. There is a 15-second delay before any temperature change is processed. The oven will power down after 72 hours.

NOTE: Turning the oven off or changing the cook mode will cancel the Sabbath Mode. If there is a loss of power while the oven is in Sabbath Mode, the oven will not resume cooking in the Sabbath Mode once power is restored.

Self-Clean Mode

The bottom oven is self-cleaning. Using heat up to 900°F (482°C), the oven will self-clean the inside of the cook cavity in approximately 4.5 hours.

NOTE: For the Double Wall Oven, while one oven is in self-clean mode the other will not be functional. Additionally, the top and bottom ovens cannot be self-cleaned at the same time.

NOTE: The oven door will not unlock until the oven cavity temperature is below 500°F (260°C).

To initiate a self-clean,

1. Ensure the cook cavity is empty and remove all oven racks.

NOTE: Failure to remove the oven rack will cause the rack to discolor. Failure to remove the roller rack may harm the rack's rolling mechanism.

2. Set the oven mode dial to Self-Clean.
3. Press and hold the Lock key for 3 seconds. The self-clean will initiate.

 **WARNING:** The oven is extremely hot during self-clean. DO NOT touch or attempt to use until self-clean is complete.

4. If terminating a self-clean is required, turn the oven mode dial to Off.
5. When self-cleaning is complete, the oven will tone and turn off automatically.

Section 4

Info Mode

Overview of the Info Mode

From the Info Mode, the user can

- Adjust oven sounds
- Adjust display settings
- Adjust oven units and measurements
- Access help topics and general cooking information
- Update oven software
- Access version information
- Access installer setup

To access the Info Mode, simply press the Info key when the oven is off (Figure 4.1).

Adjusting Oven Sounds

The user can change the oven's volume and individually turn on and off the different oven tones.

To adjust the speaker volume,

1. Ensure that the CookWheel is turned to off.
2. Press the Info key.
3. Scroll to and select Oven Setup.
4. Scroll to and select Sound.
5. Scroll to and select Volume.
6. Turn the inner CookWheel knob left or right to adjust the sound (Figure 4.2).
7. Press the Start key to confirm the adjustment.
8. Press the Back key to back out of the volume adjustment screen and return to the main Info Screen.



Figure 4.1: Oven Off

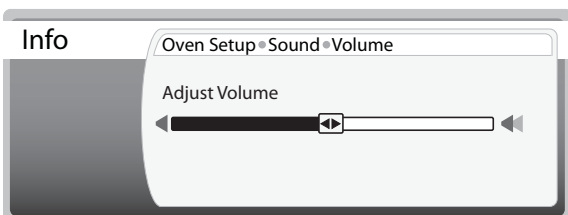

Figure 4.2: Adjust Volume

To turn on and off oven sounds,

1. Ensure that the CookWheel is turned to off.
2. Press the Info key.
3. Scroll to and select Oven Setup.
4. Scroll to and select Sound.
5. Scroll to and select Select.
6. Use the inner CookWheel knob to scroll to and select the sound to be turned on or off (Figure 4.3). By default, all oven sounds are turned on.
 - Preheat is Done: This sound indicates the oven has completed the preheat cycle and has reached the correct cooking temperature. When this sound is turned on, the oven will chime every five minutes until the user either cancels or starts the cook cycle.
 - 80% Cooking Reminder: This sound indicates the cook cycle is 80% complete. If the user chooses to not address the oven at this point, a chime will sound at 15 and 30 seconds. After 30 seconds, the oven will resume cooking.
 - 100% Cooking Reminder: This sound indicates the cook cycle is complete. The oven will chime every 8 seconds until the oven door is opened or the user selects an adjustment option.
 - Valid Selection: This sound indicates a valid selection has been made.
 - Invalid Selection: This sound indicates an invalid selection has been made.
7. Press the Back key to exit the Select screen and return to the main Info screen.

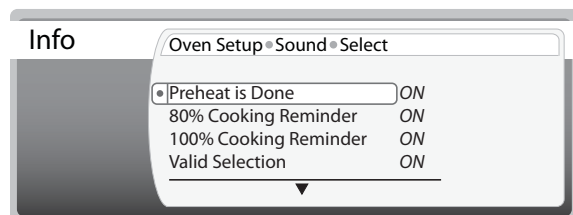

Figure 4.3: Sound Select

Adjusting Display Settings

To adjust the brightness of the oven display(s),

1. Ensure that the CookWheel is turned to off.
2. Press the Info key.
3. Scroll to and select Oven Setup.
4. Scroll to and select Display.
5. For Double Wall Oven models only, select “Top Oven” or “Bottom Oven” (Figure 4.4).
6. If “Top Oven” was selected, scroll to and select “Brightness.”
7. Adjust the brightness to the desired setting by turning the inner CookWheel knob left or right (Figure 4.5).
8. Press Start to confirm selection.
9. Press Back to return to previous screens.

To adjust the color of the Speedcook oven display,

1. Ensure that the CookWheel is turned to off.
2. Press the Info key.
3. Scroll to and select Oven Setup.
4. Scroll to and select Display.
5. For Double Wall Oven models only, select Top Oven (Figure 4.4).

NOTE: The color cannot be adjusted on the bottom oven display if Bottom Oven is selected.

6. Scroll to and select Colors.
7. Change the color to the desired setting by turning the inner CookWheel knob left or right (Figure 4.6).
8. Press Start to confirm selection.
9. Press Back to return to previous screens.

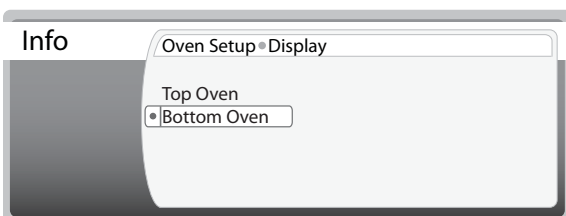

Figure 4.4: Select Top or Bottom Oven

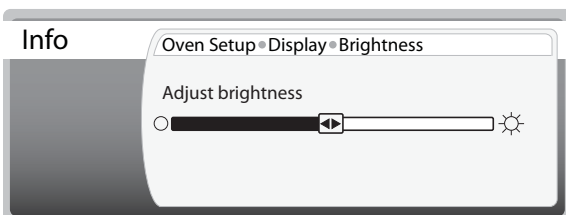

Figure 4.5: Adjust Brightness

Adjusting the Oven's Units & Measurements

The oven defaults to Fahrenheit. To change between Fahrenheit and Celsius,

1. Ensure that the CookWheel is turned to off.
2. Press the Info key.
3. Scroll to and select “Oven Setup.”
4. Scroll to and select “Units & Measurements.”
5. Scroll to and select “Temperature.”
6. Turn the inner CookWheel knob to scroll to the desired temperature measurement (Figure 4.7). The arrow indicates which setting is selected.
7. Press Back to return to previous screens.

Accessing Help Topics and General Cooking Information

The Speedcook oven comes equipped with a variety of helpful hints that cover a range of topics. This information is located in two places - Help Topics and Oven Tips.

To access Help Topics or Oven Tips,

1. Ensure that the CookWheel is turned to off.
2. Press the Info key.
3. Scroll to and select either Help Topics or Oven Tips.
4. Press Back to return to previous screens.

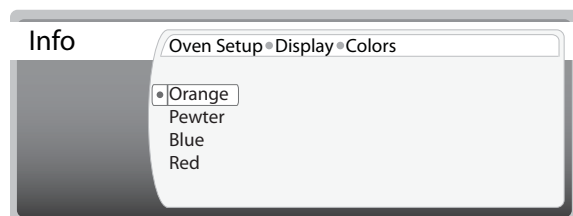

Figure 4.6: Adjust Color

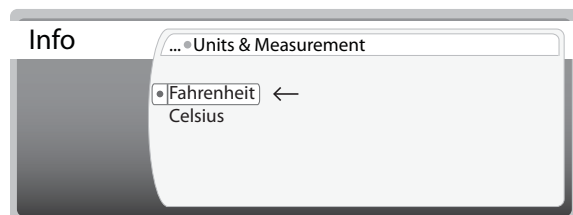

Figure 4.7: Changing Temperature Units

Updating the Oven Software

TurboChef® periodically releases software updates (located at www.turbochef.com or call customer service for assistance). The oven can be updated via USB flash drive (not included with the oven).

⚠ CAUTION: Software updates are generation specific. Installing Gen 2 software on a Gen 1 oven (and vice versa) will disable the oven. Replace the SD Card to restore oven operation (see page A.18).

NOTE: When the oven's software is upgraded, any cook settings in View Last Cooked (10) in the Favorites mode will be lost. To permanently save these settings prior to updating software, see page 2.9.

To update the oven's software,

1. Ensure the oven is in Favorites.
2. Press the Info key.
3. Scroll to and select Oven Setup.
4. Scroll to and select Software Update.
5. Insert the USB flash drive into the USB port located on top of the oven's control panel (Figure 4.8).
6. Press Start or the inner CookWheel knob to select Update Software (Figure 4.9).

NOTE: A USB extension cable (P/N: 103194) is available for easy access to the port. Contact TurboChef customer service for more information.

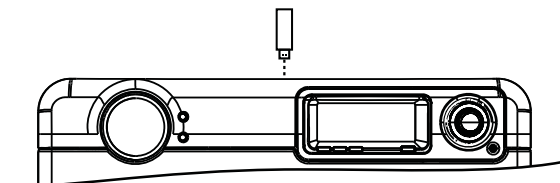

Figure 4.8: Inserting USB Flash Drive

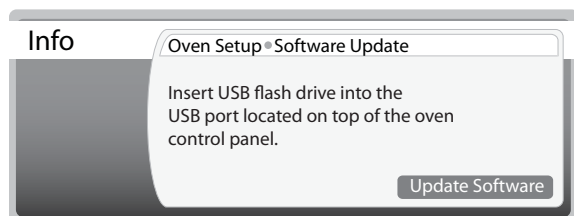

Figure 4.9: Insert USB Flash Drive Screen

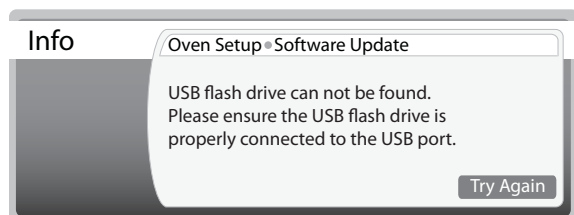

Figure 4.10: USB Flash Drive Can Not be Found Screen

NOTE: If the USB flash drive is not detected by the oven, a message will appear (Figure 4.10). Ensure the USB flash drive is correctly inserted and press Start or the inner CookWheel knob to continue. The oven will continue to display this screen until the user selects Cancel or a USB flash drive is detected.

⚠ CAUTION: DO NOT press any keys or attempt to operate the oven until the software update completes.

Backing Up/Restoring Favorites

If for some reason the SD card must be replaced, you must back up Favorites to retain them.

To back up favorites before SD card replacement,

1. Ensure the oven is in Favorites.
2. Press the Info key.
3. Scroll to and select Oven Setup.
4. Select "Backup/Restore Customizations."
5. Select "Backup to your USB Drive."
6. Insert the USB flash drive into the USB port located on top of the oven's control panel (Figure 4.8) and select "Begin."

To restore favorites after SD card replacement,

1. Follow steps 1-4 above.
2. Select "Restore from your USB Device."
3. Insert the USB flash drive into the USB port located on top of the oven's control panel (Figure 4.8) and select "Begin."

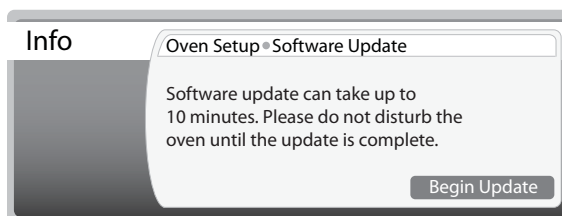

Figure 4.11: Begin Update Screen



Figure 4.12: Logo Screen

Accessing the Version Information

To access the software version number,

1. Ensure that the CookWheel is turned to off.
2. Press the info key
3. Scroll to and select Oven Setup.
4. Scroll to and select Version Information.

Installer Setup

Use the Installer Setup mode to test individual oven components by turning them on or off and to set different configuration settings for the oven. To access Installer Setup:

1. From the Info Mode, select Oven Setup.
2. From Oven Setup, select Installer Setup.
3. Input the code 042259 (Figure 4.13).

Top (or Single Wall) Oven Component Tests

Select “Top Oven” to individually turn on and off the following components (see Figure 4.14):

- Top and Bottom Blowers
- Top Heaters
- Magnetrons
- Upper Door Lock

Bottom Oven Component Tests

NOTE: Not applicable for single wall ovens.

Select “Bottom Oven” to individually turn on and off the following components (see Figure 4.15):

- Heaters
- Lower Door Lock

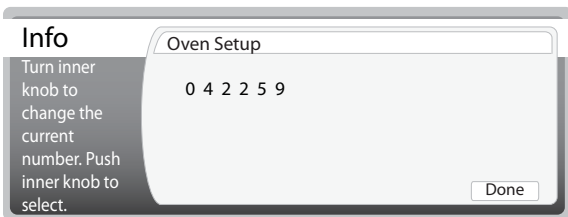

Figure 4.13: Input Password

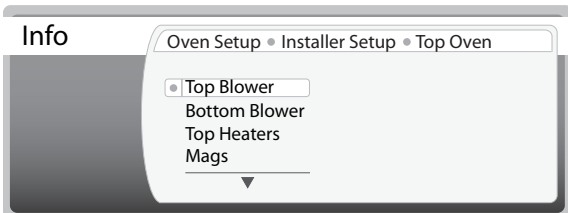

Figure 4.14: Top Oven Component Options

Oven Configuration

From the Installer Setup screen, scroll down and select “Oven Configuration” to configure the oven for double wall or single wall (Figure 4.16).

⚠ CAUTION: If the oven is not set to the proper configuration, it will not operate correctly.

NOTE: If the SD card is replaced, the oven must be reconfigured to the correct setting.

AC Voltage Configuration

⚠ WARNING: DO NOT reconfigure the operating voltage of the oven to accommodate existing voltage supply or the oven will not operate correctly. Change this setting only if instructed by TurboChef.

From the Installer Setup screen, scroll down and select AC Voltage Configuration to specify between 208 and 240 VAC (Figure 4.17).

Simulation/Demo State, and printf Mask

Simulation State, Demo State, and printf Mask are configurations specific to manufacturer use. Do not activate these configurations unless expressly instructed by TurboChef.

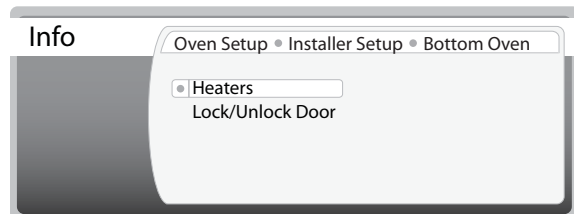

Figure 4.15: Bottom Oven Component Options

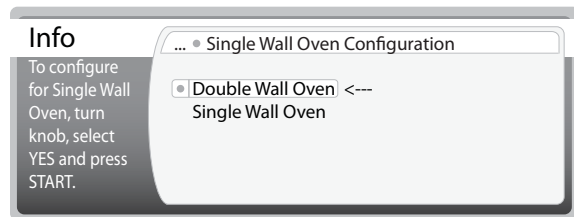

Figure 4.16: Oven Configuration

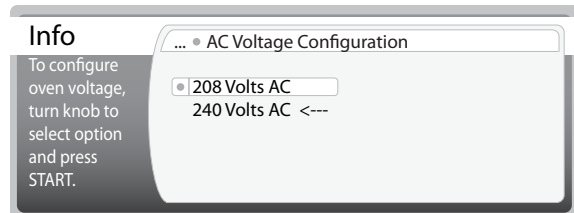

Figure 4.17: AC Voltage Configuration

Section 5

Oven Systems

Convection System - Speedcook Oven

The Speedcook oven convection system is designed to rapidly heat, clean, and recirculate air into the cook cavity. This section contains information about the following components:

- Blower motor (bottom)
- Blower motor (top)
- Blower motor controller (BMSC)
- Heater assembly
- Jetplate (bottom)
- Jetplate (top)
- Stirrer motor and assembly

For information on accessing and removing parts, and for part numbers, see the Appendix.

Blower Motor (Bottom)

The bottom blower motor runs on varied 3-phase power to force the air into the upper oven cavity. The motor is controlled by a proprietary controller.

The bottom blower motor can be tested in **INSTALLER SETUP MODE** (see page 4.4).

Blower Motor (Top)

The top blower motor runs on varied 3-phase power to force the air into the upper oven cavity. The motor is controlled by a proprietary controller.

The top blower motor can be tested in **INSTALLER SETUP MODE** (see page 4.4).

Blower Motor Controller (BMSC)

The blower motor controller is proprietary and will only operate the convection motors described above. The motor controller is controlled on command from the control board and a 0-10VDC speed command from the control board.

The blower motor controller can be tested in **INSTALLER SETUP MODE** by testing the blower motors (see page 4.4). For additional troubleshooting, see page 6.3.

Heater Assembly

The Speedcook oven heater assembly consists of three elements. The elements are voltage specific and cannot operate properly without the correct voltage applied. Confirm incoming voltage matches the oven's specifications. During preheat, all three elements are energized.

The K1 solid state relay (see page 5.12) controls L1 voltage to the two primary elements while the K8 relay (see page 5.10) controls L1 voltage to the preheat element. The K9 relay (see page 5.11) controls L2 voltage to all three elements.

NOTE: For 208 volt units, preheat amperage is at 30.8 amps and once the temperature has been reached, the operating amperage is at 20.5 amps.

NOTE: For 240 volt units, preheat amperage is at 28.8 amps and once the temperature has been reached, the operating amperage is at 19.2 amps.

Jetplate (Bottom)

The bottom jetplate channels air that is generated from the bottom blower motor.

Jetplate (Top)

The top jetplate channels air that is generated from the top blower motor. This air passes through a stirrer before entering the cook cavity through the jetplate holes.

 **CAUTION:** The top jetplate is ceramic and may crack or break if mishandled. Be careful when removing or reinstalling it.

Stirrer Motor and Assembly

The stirrer is responsible for evenly distributing hot air and microwaves that are launched from the top of the oven into the cook cavity. The stirrer is driven by a motor that remains on during a cook cycle. When the oven is cooling down, the stirrer motor turns off when the cook cavity temperature recedes below 160°F (71°C).

To visually test stirrer motor operation, go to Bake, which will automatically turn on the stirrer, the stirrer is visible through the upper jetplate holes.

Convection System - Lower Oven (Double Wall Oven Only)

The lower oven convection system is designed to rapidly heat and recirculate air into the cook cavity. This section contains information about the following components:

- Broil element
- Bake element
- Convection element
- Convection fan motor

For information on accessing and removing parts, and for part numbers, see the Appendix.

Broil Element

The broil element consists of independently-operated inner and outer elements. The inner broil element's L1 voltage is controlled by the K12 solid state relay's output "B" while the L2 voltage is controlled by the K13 relay's N.O. terminal. The outer broil element's L1 voltage is controlled by the K12 solid state relay's output "A" while the L2 voltage is controlled by the K13 relay's N.O. terminal.

Bake Element

The bake element's L1 voltage is controlled by the K11 solid state relay's output "B" while the L2 voltage is controlled by the K13 relay's N.O. terminal.

Convection Element

The convection element's L1 voltage is controlled by the K11 solid state relay's output "A" while the L2 voltage is controlled by the K13 relay's N.O. terminal.

Convection Fan

The convection fan motor is powered by 120 VAC L2 voltage, which is controlled by the selector switch's terminal "3." When a convection cycle is selected, the switch to terminal 3 is closed and the convection fan motor is supplied voltage. The convection fan will continue to run until the selector switch is turned to a non-convection cycle and the switch to terminal 3 is opened.

For Gen 2 ovens, operation is the same through the CookWheel, but power is received from terminal RBJ20-2 of the relay board.

Speedcook Oven Door

This section contains information about the following:

- Removing/reinstalling the Speedcook oven door
- Door skin replacement
- Left lock motor assembly
- Right lock motor assembly
- Measuring RF leakage for microwave safety
- Halogen light assembly

For information on accessing and removing parts, and for part numbers, see the Appendix.

The proper fit and adjustment of the oven door is essential for safe and reliable oven operation.

Removing/Reinstalling the Speedcook Oven Door

To remove or reinstall the Speedcook oven door, follow the steps below. Refer to Figure 5.1.

 **CAUTION: DO NOT** lift the oven door by the handle. Lifting the oven door by the handle can damage the oven door and cause it to misalign.

1. Ensure the oven has cooled to at least 160°F (71°C).
2. To gain access to the right and left upper-hinge pockets, remove the oven from the cabinet approximately 7" (178 mm).
3. Remove the insulation covers (1) and insulation (2).
4. Remove the locking screw (3) from the receivers (one on each side).
5. Open the door completely.
6. Pull both hinge locks forward.
7. Raise the door until the hinge locks prevent the door from closing any further.
8. Hold the door by the sides and lift the door out of the hinge pockets.

9. To install a new door, hold the door by the sides and slide the door into the hinge pockets in the same manner the door was removed.
10. Open the door completely.
11. Push both hinge locks back into their original positions.
12. Close the door.
13. Reinstall the locking screws, insulation, and insulation covers.
14. Ensure the door opens and closes freely.
15. Push the oven back into its original position.
16. Perform a MW leakage test (see page 5.4).

Door Skin Replacement

If the oven door skin has sustained damage or if a new color is wanted, the door skin can be replaced without replacing the entire door. Follow the steps below and refer to Figure 5.2.

1. Follow the Removing/Reinstalling the Upper Oven Door steps 1-8 (see page 5.2).
2. Place the oven door on a flat surface and ensure that all surfaces are protected from damage.
3. Remove the four phillips screws (A) from the bottom and the two door handle bolts (B). Retain screws (A) and bolts (B) and handle (C) for use on replacement door skin.
4. Install the new door skin using the hardware from step 3.

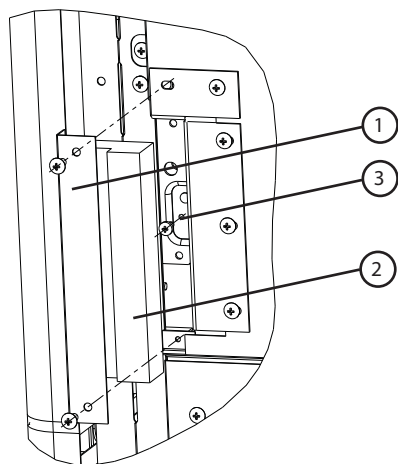

Figure 5.1: Hinge Pocket

5. Follow the Removing/Reinstalling the Upper Oven Door steps 9-16 (adjacent).

⚠ CAUTION: A microwave leakage test **MUST** be performed! See page 5.4.

Left Lock Motor Assembly

The left lock motor assembly consists of a motor, locking mechanism for the left side of the Speedcook oven door, and three switches (primary, light, and lock) that activate when a cam is turned while the door closes.

The light switch controls the oven cavity light. The light turns off when the door is closed, unless the oven light switch (see page 2.1) is pressed.

The left lock switch closes to supply power to the locking mechanism while the door is closed.

For Gen 1 ovens, the left (primary) interlock switch (when closed in conjunction with the right interlock switches) supplies power to the K3 and K4 relays, which close and distribute power to the right and left high-voltage transformers, allowing for microwave operation.

For Gen 2 ovens, the door switch circuit starts and returns on the control board (primary switch = J15-7 and J15-8). Control voltage leaves the control board to the relay board for relay operation.

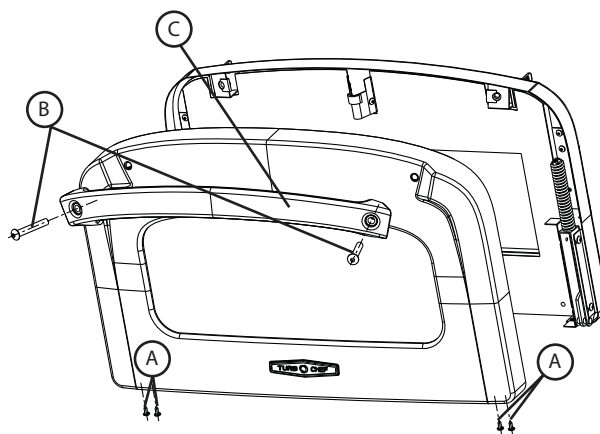

Figure 5.2: Speedcook Oven Door Detail

Right Lock Motor Assembly

The right lock motor assembly consists of a motor, locking mechanism for the right side of the Speed-cook oven door, and three switches that activate when a cam is turned while the door closes.

For Gen 1 ovens, when the secondary, monitor, and lock switches are closed, the I/O control board opens the K2 relay to prevent a direct short to the 20-amp fuse.

The right lock switch closes to supply power to the locking mechanism when the cam is turned while the door is closed.

For Gen 1 ovens, the right switches (when closed in conjunction with the primary switch) supply power to the K3 and K4 relays, which close and distribute power to the right and left high-voltage transformers, allowing for microwave operation.

For Gen 2 ovens, the door switch circuit starts and returns on the control board (secondary switch = J15-9 and 10; monitor switch = J15-5 and 6). Control voltage leaves the control board to the relay board for relay operation.

Measuring RF Leakage for Microwave Safety

An RF (microwave) leakage test must be performed at the conclusion of the following service tasks:

- Door removal, replacement, and/or adjustment
- Door gasket removal, replacement, and/or adjustment
- Waveguide removal and /or replacement
- Magnetron removal and/or replacement
- Door skin removal and replacement

⚠ WARNING: If the unit fails the microwave leakage test (leakage greater than $5\text{mW}/\text{cm}^2$), the oven must be taken out of service immediately until the defect is corrected. In addition, the CDRH Regulation 21 Subpart C, 1002.20 requires that leakage readings of over $5\text{mW}/\text{cm}^2$ must be reported to the manufacturer.

To measure RF leakage,

1. Access the Installer Setup Mode.
 - a. Press the “Info” key.
 - b. Select “Oven Setup.”
 - c. Select “Installer Setup.”
 - d. Input the password 042259.

- e. Select “Top Oven.”
 - f. Select “Mags.” For Gen 1 ovens, the Cook-Wheel must not be in the Off position.
2. Place a water load into the cook cavity (Figure 5.3). Water load must conform to the following specifications:
 - Volume: $275\text{ ml} \pm 15\text{ ml}$
 - Temperature: $68^\circ\text{F} \pm 9^\circ\text{F}$ ($20^\circ\text{C} \pm 5^\circ\text{C}$)
 - Vessel: Low form, 600 ml beaker with an inside diameter of approximately 3.35” (85 mm) and made of Pyrex[®] or equivalent.
3. Close the oven door and turn on the magnetrons.
4. Position the microwave survey meter as shown in Figure 5.4.
5. Measure microwave emission:
 - a. Leave the magnetrons on for 60 seconds.
 - b. While the magnetrons are on, measure microwave emission around the door, moving the meter sensor at 1 inch/second. As microwave leakage is observed moving the sensor at 1 inch/second, note any meter spike areas that come close to $5\text{mW}/\text{cm}^2$ for later re-measurement.
 - c. Replace the water load every 60 seconds until the test is completed.
6. Once done scanning the entire door, replace the water load.
7. Close the oven door. While the magnetrons are on, return the meter probe to any “meter spike” areas and allow the probe to remain in the “spike” area for 15 seconds per area. Note the highest reading obtained in each area.



Figure 5.3: Water Load Placement

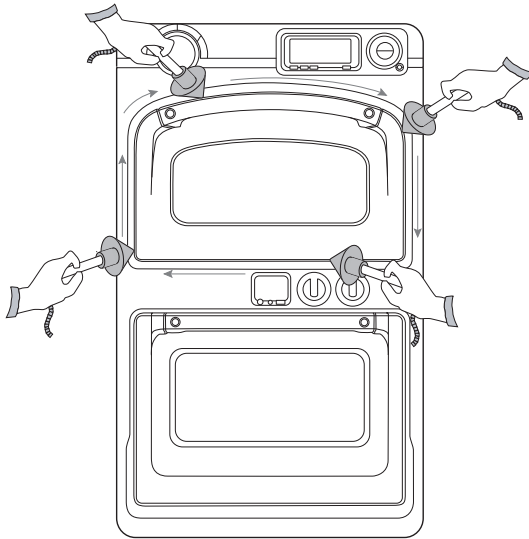

Figure 5.4: Survey Meter Placement

NOTE: There may be several places on the door where this procedure needs to be done. If so, start out with a fresh water load each time a new area is measured, or if measurement of an area takes longer than 60 seconds.

8. After each test is complete, open the oven door and dispose of the hot water.

Halogen Light Assembly

The halogen light assembly consists of 2 lights that are powered when the door is opened or when the oven light switch is pressed (see page 2.1). When the door is opened, the left side lock motor assembly's N.C. light switches supply power from the 12 VDC power supply to the lights. Likewise, if the oven light switch (see page 2.1) is pressed, power is supplied to the left and right halogen lights as well.

⚠ CAUTION: DO NOT touch the bulb with bare fingers; rather, use gloves, cloth, or tissue when handling the bulb. If the bulb is accidentally touched, clean it with isopropyl alcohol before applying power.

⚠ CAUTION: To avoid burns, ensure the oven cavity has had adequate time to cool before performing the below procedure.

To replace a bulb in the Speedcook oven,

1. Remove the halogen light cover using the tool provided with kit RWD-3014.

2. Remove the bulb by gently pulling it out of the socket.
3. Install the new bulb.
4. Reinstall the cover, using the tool provided with kit RWD-3014 to tighten it.

Lower Oven Door (Double Wall Oven Only)

This section contains information about the following:

- Removing/reinstalling the lower oven door
- Halogen bulb replacement

For information on accessing and removing parts, and for part numbers, see the Appendix.

Removing/Reinstalling the Lower Oven Door

To remove or reinstall the lower oven door, follow the steps below.

⚠ CAUTION: DO NOT lift the oven door by the handle. Lifting the oven door by the handle can damage the oven door and cause it to misalign.

1. Ensure the lower oven has cooled below 160°F (71°C).
2. To gain access to the right and left lower-hinge pockets, remove the oven from the cabinet approximately 7" (178 mm).
3. Open the door completely.
4. Pull both hinge locks forward.
5. Raise the door until the hinge locks prevent the door from closing any further.
6. Hold the door by the sides and lift the door out of the hinge pockets.
7. To install a new door, hold the door by the sides and slide the door into the hinge pockets in the same manner the door was removed.
8. Open the door completely.
9. Push both hinge locks back into their original positions.

10. Close the door.
11. Ensure the door opens and closes freely.
12. Push the oven back into its original position.

Halogen Bulb Replacement

⚠ CAUTION: DO NOT touch the bulb with bare fingers; rather, use gloves, cloth, or tissue when handling the bulb. If the bulb is accidentally touched, clean it with isopropyl alcohol before applying power.

⚠ CAUTION: To avoid burns, ensure the oven cavity has had adequate time to cool before performing the below procedure.

To replace a bulb in the lower oven (use RWD-3016),

1. Gently pry the halogen light cover from the oven cavity wall using a flat-surfaced object. Be careful to not damage the porcelain coating on the oven cavity wall.
2. Remove the bulb by gently pulling it out of the socket.
3. Install the new bulb.
4. Reinstall the cover, ensuring that it snaps into place.

Microwave System

This section contains information about the following components:

- Doubler circuit, voltage
- High-voltage capacitors
- High-voltage diodes
- High-voltage transformers
- Magnetrons
- Stirrer motor and assembly
- Waveguides

For information on accessing and removing parts, see the Appendix.

Doubler Circuit, Voltage

The microwave system consists of a magnetron and voltage doubler circuit. The voltage doubler circuit consists of a special step-up transformer, a capacitor, and a diode. Two separate transformers are incorporated; one is the 1-10 step-up, multiplying the incoming voltage by 10, the other is the filament transformer that supplies approximately 3.5 VAC to the magnetron filaments to warm them before the 4000+ volts are applied. This function extends the life of the components. The oven uses two magnetrons, each magnetron circuit is separate and independent.

High-Voltage Capacitors

The high-voltage capacitor works in combination with the diode to effectively double the already-high voltage from the secondary (output) winding of the transformer. The capacitor is used to store the power during the positive to negative swing of the incoming AC voltage. When the oven is connected to power, the capacitor will still have 2000+ volts setting on the terminals. During magnetron operation, the potential is 4000+ volts.

High-Voltage Diode

The high-voltage diode works in combination with the high-voltage capacitor to effectively double the 2000+ volts output voltage from the high-voltage transformer. During magnetron operation, the potential is 4000+ volts. This high voltage allows the magnetron to produce the microwave energy.

The high-voltage diode is assembled by connecting several 1000-1500 volt semiconductor diodes in a series to increase the reverse voltage capability. In the circuit, the high-voltage diode conducts to prevent the filament voltage from becoming positive, thus as the high-voltage winding of the transformer goes to 2400, the high-voltage capacitor is charged to 2000+ volts.

When the high-voltage winding starts to go toward negative, the high-voltage diode becomes non-conducting with the charged high voltage capacitor in series with the high-voltage winding. When the transformer gets to its negative peak of -2400, the voltage applied to the filament is negative 4000+ volts.

High-Voltage Transformers

The high-voltage transformers are ferro-resonant, limiting fault currents and minimizing magnetron power changes due to input voltage changes. The high-voltage transformer supplies the high voltage for the Voltage Doubler Circuit. For Gen 1 ovens, they are controlled via the K3 and K4 relays. For Gen 2 ovens, they are controlled by relays 2 and 3 on the relay board (outputs RBJ5 and RBJ4).

Wiring a High-Voltage Transformer

⚠ DANGER: Never attempt to wire or measure the secondary voltage values of the high-voltage transformers with the high-voltage transformers enabled. Lethal voltage will be present.

The proper re-installation of a high-voltage transformer is critical. Upon removing a high-voltage transformer, make sure to note where each wire was connected. Refer to the oven schematic (Section 7) detailing the proper wiring.

As shown in the schematic, transformers are installed mirror opposite and wired 180° out-of-phase. It is essential for longevity that the high-voltage transformers remain 180° out-of-phase. This can be checked by placing a volt meter across terminals T1-1 and T2-1 (primary voltage). If the meter reads 0 VAC, the high-voltage transformers are most likely wired in-phase.

As a last check, energize the microwave system and verify the voltages between the incoming voltage taps on each high-voltage transformer. Taps 1 and 2 = 208V. Taps 1 and 3 = 240V. Wiring issues must be corrected prior to returning the oven to service. Voltage at the wall must match the transformer configuration.

Magnetrons

The magnetron generates microwave energy by means of 4000+ volts supplied by the microwave circuit. Due to the very high voltage present during operation, the only safe way to test this component is by a resistance test of its filament with the power disconnected and the capacitors properly discharged.

The magnetron can have a good filament and still not operate properly. All of the testing should be completed on the other microwave components first before checking the magnetron. If all tests listed in this manual are completed for the transformer, diode, and capacitor, and all show to be within specifications, the magnetron will be the defective component.

⚠ CAUTION: Be careful to not allow debris into the waveguides when servicing the magnetrons.

Stirrer Motor and Assembly

The stirrer is responsible for evenly distributing hot air and microwaves that are launched from the top of the oven into the cook cavity. The stirrer is driven by a motor that remains on during a cook cycle. When the oven is cooling down, the stirrer motor turns off when the cook cavity temperature recedes below 160°F (71°C).

To visually test stirrer motor operation, go to Bake, which will automatically turn on the stirrer, the stirrer is visible through the upper jetplate holes.

Waveguides

The waveguides channel microwaves into the cook cavity. To prevent the life of the magnetrons from being shortened, be careful to not allow debris to enter into the waveguides when servicing the magnetrons.

Control System

This section contains information about the following components:

- Air switch (single wall oven)
- Clock
- Control board
- CookWheel control
- Display, lower oven
- Display, speedcook oven
- Electrical compartment cooling fans
- EMI filter
- Fuses
- High limit thermostats
- Latch mechanism (lower oven)
- Light switch, control panel
- M.O.V. filter
- Magnetron cooling fan
- Magnetron thermostats
- Power supply, 12 VDC
- Power supply, 24 VDC
- Relay board (Gen 2; see diagram on page 7.7)
- Relay - K2 monitor (Gen 1 oven)
- Relay - K3 T1 HV transformer (Gen 1 oven)
- Relay - K4 T2 HV transformer (Gen 1 oven)
- Relay - K5 mag cooling fan (Gen 1 oven)
- Relay - K6 right-side door lock (Gen 1 oven)
- Relay - K7 left-side door lock (Gen 1 oven)
- Relay - K8 preheat (Gen 1 oven)
- Relay - K9 L2 upper heating elements
- Relay - K10 lower door lock (Gen 1 oven)
- Relay - K13 L2 lower oven heating elements
- RJ Cables
- RTD
- SD Card
- Selector switches
- Solid state relay - K1 L1 Speedcook oven heating elements
- Solid state relay - K11 lower oven bake and convection elements
- Solid state relay - K12 lower oven broil elements - inner and outer
- Speaker
- Temperature switch (Lower Oven)
- Transformer, clock, 12 VAC
- Thermostat, cook cavity
- Thermostat, fan control
- USB port
- Wiring harness

For information on accessing and removing parts, see the Appendix.

Air Switch (Single Wall Oven)

The air switch monitors the amount of air coming from the exhaust blower in the single wall oven. It is a fail-safe device that communicates to the control board whether or not the exhaust blower is working.

Clock

For Gen 1 ovens, pins 1 and 5 supply voltage to the clock for operation from the clock transformer. For Gen 2 ovens, pins 1 and 5 supply voltage to the clock from terminals RBJ18-1 and RBJ18-2 on the relay board. For all ovens, pins 2 and 3 supply control signals to the control board, which allows the clock to tell the control board when the speaker needs to chime (terminal P24 on Gen 1 ovens and terminal J21 on Gen 2 ovens).

Control Board

The control board controls each electrical component of the oven. See section 7 for schematics.

CookWheel Control

When the CookWheel is turned to any position except “Off” and “Favorites,” it closes its normally open (N.O.) switch and the upper and lower cooling fans are activated. Also, the three upper oven heating elements receive L2 voltage and the stirrer motor activates. In any position other than “Off” and “Favorites” the control board also closes the relays that supply L1 voltage to the three heating elements in the upper oven, preheating the oven during the selection process.

Display, Lower Oven

The lower liquid crystal display is the primary user interface for the lower oven.

Attaching the Lower Display Cable

 **CAUTION:** When connecting the lower display to the control board, ensure that it is connected correctly. An incorrect connection can cause the control board and/or the lower display to fail.

A twenty pin female connector connects the lower display cable to the control board. The triangle on the connector denotes pin 1. Ensure that the slot

denoted by the triangle is placed onto pin one. For Gen 1 ovens, the lower display cable is connected to the control board's P13 connector. For Gen 2 ovens, the lower display cable is connected to the control board's J9 connector.

Display, Speedcook Oven

The upper liquid crystal display is the primary user interface for the Speedcook oven. It is connected to the control board via a ribbon cable. To ensure that the cable is properly positioned, a red line is located on only one side of the cable. This red line should face downward on the upper display assembly. It should also point left on the control board. Failure to reattach the ribbon cable correctly could lead to a direct short in the control board and upper display assembly.

NOTE: In Gen 1 ovens, the upper display ribbon cable is a ground source for the control board to the oven frame.

Electrical Compartment Cooling Fans

Both the upper and lower electrical compartment cooling fans are activated when either the Cook-Wheel (top oven) or the selector switch (bottom oven) are turned to any selection other than off. Both fans are independently monitored by motion sensors that will display an error message on the display if either fan fails to function normally. It accomplishes this by sending 5 VDC pulses to the control board while the fan is spinning; these pulses occur so fast that a voltmeter will register an average reading of 2.5 VDC when the fan is spinning and a constant 5 VDC or 0 VDC when the fan is not spinning.

EMI Filter

The EMI filter helps suppress the amount of RF interference emitted by the oven and interference entering from the supply voltage.

Fuses

For Gen 1 ovens, the 15 and 20-amp fuses are housed in a fuse block. The top fuse is rated 20 amps and designated for the microwave system only. This safety fuse is designed to trip if the system attempts to operate the magnetrons when the monitor circuit

sees an open door condition. The bottom fuse is rated 15 amps. It is wired in the circuit to protect the low voltage components in the oven.

Gen 1 ovens also contain a 5-amp fuse located on the right magnetron cover. This fuse is powered by the K9 relay to provide power to the upper and lower cooling fans.

For Gen 2 ovens, the fuses are located on the relay board. Fuse 1 (right side) is rated to 20 amps, and fuse 2 (left side) is rated to 15 amps (Gen 2 ovens do not contain a 5 amp fuse).

High Limit Thermostats

The high limit thermostat is a 250 VAC, 3-pole, manual-reset thermostat with a trip point of 572°F (300°C). The thermostat interrupts power to the main convection heater in the event of an abnormal condition.

Pertaining to the double wall oven, the upper and lower ovens have independent high limit thermostats located in their respective upper and lower electrical compartments. Reset the high-limit thermostat by pressing the reset button.

Latch Mechanism (Lower Oven)

The latch mechanism automatically locks the lower oven door during the self-clean cycle to prevent exposure to the extreme temperatures used to clean the inside of the oven. The oven door can also be locked by pressing the door lock button underneath the lower display. It will not unlock unless the oven temperature is below 500°F (260°C).

Light Switch, Control Panel

The control panel light switch (see page 2.1) activates the lights in the Speedcook oven.

M.O.V. Filter

The M.O.V. filter limits voltage spikes coming into the oven system. If a substantial voltage spike enters the system, the M.O.V. may short as a result of protecting the system. Symptoms of a shorted M.O.V. filter are accompanied by a tripped circuit breaker that will continually trip when reset. Also look for a burned or damaged M.O.V.

Magnetron Cooling Fan

The magnetron cooling fans supply air to the magnetrons. For Gen 1 ovens, they are actuated by the K5 relay. For Gen 2 ovens, they are actuated by relay 4 on the relay board (RBJ19-1). At the end of a microwave cook cycle, the cooling fans will continue to operate for an additional 2 minutes (on older versions of the control software, the magnetron cooling fans run for an additional 5 minutes).

Magnetron Thermostats

The magnetron thermostats are wired in-series with the input voltage of the HV transformers. They open at 280°F (138°C).

Power Supply, 12 VDC

The 12 VDC power supply supplies power to the halogen oven lights.

Power Supply, 24 VDC

The 24VDC power supply supplies voltage to the control board (and relay board for Gen 2 ovens).

Relay Board (Gen 2 Only)

Gen 2 ovens contain a relay board consisting of the fuses (page 5.9), clock transformer, and all relays described below. If any of these components fail, except the fuses, the entire relay board must be replaced. See page 7.7 for a schematic with test point locations.

- Relay 1: Monitor
- Relays 2 and 3: HV transformers
- Relay 4: Magnetron cooling fan
- Relay 5: Door lock, upper left
- Relay 6: Door lock, upper right
- Relay 7: Cooling fan, upper
- Relay 8: Stirrer motor
- Relay 9: Door light, upper
- Relay 10: Door lock, lower
- Relay 11: Cooling fan, lower
- Relay 12: Convection fan
- Relay 13: Door light, lower
- Relay 14: Pre-heater

Relay - K2 Monitor (Gen 1 Oven)

The K2 relay is a 30 amp, double-pole, double-throw, class F, 24 VDC relay coil. It is used in the magnetron circuit along with the K3 and K4 relays. If the door is opened during a cook cycle, and the K3 or K4 relays are still closed due to a door switch failure, this relay will cause L1 and L2 voltage to short circuit and blow the 20-amp fuse. The system is designed to protect the user in the case of a door switch failure. The K2 relay coil is supplied with 24 VDC power except when the door is open or oven power is disconnected.

Relay - K3 T1 HV Transformer (Gen 1 Oven)

The K3 relay is a 30 amp, double-pole, double-throw, class F, 24 VDC relay coil. This relay sends L1 voltage to the T1 transformer.

Relay - K4 T2 HV Transformer (Gen 1 Oven)

The K4 relay is a 30 amp, double-pole, double-throw, class F, 24 VDC relay coil. This relay sends L1 voltage to the T2 transformer.

Relay - K5 Mag Cooling Fan (Gen 1 Oven)

The K5 relay is a 30 amp, double-pole, double-throw, class F, 24 VDC relay coil. This relay activates the magnetron cooling fan during and after magnetron operation.

Relay - K6 Right Side Door Lock (Gen 1 Oven)

The K6 relay is a 30 amp, double-pole, double-throw, class F, 24 VDC relay coil. This relay controls the right side door lock motor.

Relay - K7 Left Side Door Lock (Gen 1 Oven)

The K7 relay is a 30 amp, double-pole, double-throw, class F, 24 VDC relay coil. This relay controls the left side door lock motor.

Relay - K8 Preheat (Gen 1 Oven)

The K8 relay is a 30 amp, double-pole, double-throw, class F, 24 VDC relay coil. The K8 relay controls the L1 voltage to the Speedcook oven's preheat element. When the CookWheel is turned to begin the selection process, the control board sends

24 VDC to the activating terminals of the relay. The N.O. switch closes to send L1 voltage to the preheat element. When the RTD registers that the oven has reached 80% of the preset temperature, the control board stops sending 24 VDC to the K8 relay and the switch opens to turn off the preheat element.

Relay - K9 L2 Speedcook Heating Elements

The K9 relay is a 120 VAC single-pole, double-throw, relay. This relay supplies L2 voltage to the three Speedcook oven heating elements. On Gen 1 ovens, this relay also supplies L2 voltage to the upper and lower cooling fans inline with the 5-amp fuse.

Relay - K10 Lower Door Lock (Gen 1 Oven)

The K10 relay works in conjunction with the lower oven's plunger light switch to activate the lower oven lock motor. Terminal 2 on the selector switch constantly supplies 120 VAC to the K10 relay's common. The control board activates the K10 relay's N.O. switch to the lower oven lock motor by using a circuit inline with the plunger light switch.

This means that the K10 relay will only activate the lower oven lock motor when the oven door is closed (plunger pressed).

Relay - K13 L2 Lower Heating Elements (Double Wall Oven Only)

The K13 relay is a 120 VAC single-pole, double-throw, relay. This relay supplies L2 voltage to the four lower oven heating elements.

RJ Cables

The RJ cables connect the control board to the CookWheel and lower oven Mode and Temperature switches.

RTD

The RTD uses resistance to register cook cavity temperature. As heat increases in the oven, so does the resistance registered in the RTD. This allows the control board to accurately monitor the temperature in the oven and activate/deactivate the elements as needed. Refer to the ohms/temperature chart for testing (page 6.5).

SD Card

The SD card, which is inserted into the control board, stores the control software for the oven.

⚠ CAUTION: When inserting an SD card, always ensure it is set to unlocked; otherwise the oven will not properly save settings. **DO NOT** remove the card when the oven is powered up.

Before replacing the SD card, back up Favorites to a USB drive (page 4.3)

After replacing the SD card,

1. Restore Favorites from the USB drive (page 4.3).
2. Set the Oven Configuration to single or double (page 4.4).

Selector Switches

When the CookWheel or the lower oven selector switch is turned to a setting other than off, the switch between terminals 1 and 2 is closed. This supplies L2 voltage to the lower cooling motor, the activating terminal on the K13 lower heating element relay, and the CookWheel to supply power to the upper cooling motor. In other words, whenever an oven is turned on, the electrical compartment cooling fans also turn on. In Gen 1 ovens, the fans will turn off when the oven is turned off. In Gen 2 ovens, the cooling fans will remain on for an additional two minutes after the oven has been turned off.

NOTE: The electrical cooling fans will also turn on at any time regardless of the selector switch position if the temperature within the upper electrical compartment exceeds 140°F (60°C), or if the temperature within the lower electrical compartment exceeds 160°F (71°C).

In double wall ovens, the K13 N.O. closes and supplies L2 voltage to the bake, convection, inner broil, and outer broil elements. When a convection cycle is selected, the convection fan is also powered and will remain on until the convection cycle is no longer selected.

Solid State Relay - K1 L1 Speedcook Heating Elements

The K1 solid state relay is a 240 VAC, dual 40 amp relay. This relay supplies L1 voltage to the Speedcook oven's heating elements. The control board sends 24 VDC to the K1 solid state relay to “open” and “close” both sides of the solid state relay, which helps ensure absolute temperature control.

Solid State Relay - K11 Bake and Convection Elements (Double Wall Oven Only)

The K11 solid state relay is a 240 VAC, dual 40 amp relay. This relay supplies L1 voltage to the lower oven's bake and convection elements (24 VDC control voltage).

Solid State Relay - K12 Broil Elements: Inner and Outer (Double Wall Oven Only)

The K12 solid state relay is a 240 VAC, dual 40 amp relay. This relay controls the L1 voltage to the lower oven's inner and outer broil elements. The control board sends 24 VDC to the K12 SSR to independently “open” and “close” each side of the SSR, over 100 times per second, for absolute temperature control.

Speaker

The speaker provides audible feedback to the operator whenever a key is pressed or a task (such as a cook cycle) is completed, etc. See page 4.1 for adjustments.

Temperature Switch (Lower Oven)

The temperature switch uses a six-wire (RJ) cable to communicate the temperature selection to the control board.

Transformer, Clock, 12 VAC

The 12 VAC transformer supplies voltage to the Speedcook oven clock. For Gen 2 ovens, the 12 VAC transformer is located on the relay board (terminals RBJ18-1 and 2).

Thermostat, Cook Cavity

To prevent temperature from running away during normal oven operation, each oven is monitored by a thermostat (270°F switch for Speedcook cavity and 280°F for the lower oven cavity in double wall ovens). In both the single and double wall oven, the switch(es) are wired to the control board through P7-18 and P8-6 (Gen 1) or pins J15-18 and J15-19 (Gen 2).

Thermostat, Cooling Fan Control

The cooling fan control thermostats are normally-open snap switches that will close if the temperature within the upper electrical compartment exceeds 140°F (60°C), or if the temperature within the lower electrical compartment exceeds 160°F (71°C). They supply voltage from the terminal block to the upper and lower cooling fans, allowing them to operate if they are needed after the CookWheel or selector switch has been turned to the off position. If either thermostat closes, both cooling fans will be powered on.

USB Port

The USB port allows the oven operator to load software updates from a USB drive. For instructions, see page 4.3.

Connecting the USB Board (Gen 1 Oven)

The USB board connects to the control board via a 10-pin molex cable (for USB board location, see page A.7). Plug one end of the molex cable into the control board's P25 connector, as shown in Figure 5.4. Ensure that, when facing the oven, the cable's red stripe is on your right.

NOTE: The picture below shows the molex cable not completely inserted, ensure you completely insert the molex cable.

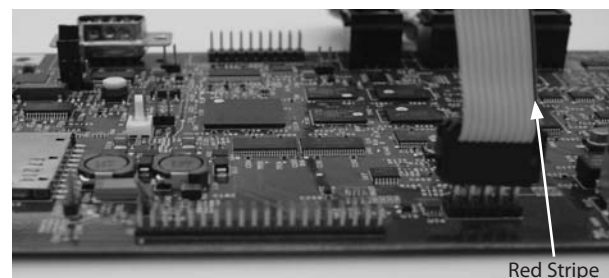

Figure 5.4: Control Board, Connecting to USB Board

Plug the the other end of the molex cable into the USB board as shown in Figure 5.5. Ensure that, when facing the oven, the red stripe is on your left and the two empty sockets are on your right.

NOTE: The picture below shows the molex cable not completely inserted, ensure you completely insert the molex cable.

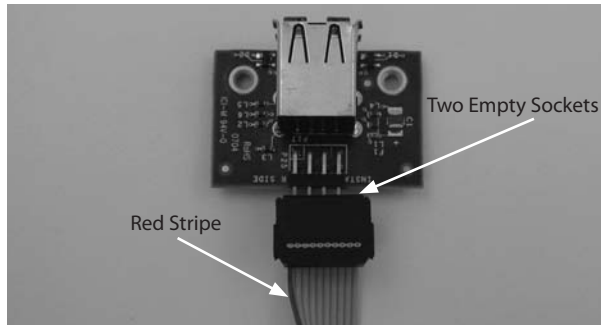

Figure 5.5: USB Board, Connecting to Control Board

Wiring Harness

The wire harness distributes power to the oven's electrical components. See section 7 for schematics.

Exhaust System

This section contains information about the following components:

- Catalytic converter
- Exhaust Blower
- Vent catalyst

Catalytic Converter

The catalyst functions by substantially lowering the combustion temperature of grease entrained in the air path to approximately the same temperature of the airflow; thus the grease burns and breaks down into CO_2 and H_2O as it passes through the catalytic converter. The catalyst will operate most efficiently at temperatures above 475°F (246°C). The catalyst material is very sensitive to certain chemical compounds. Irreversible damage can occur if the catalyst is exposed to cleaning chemicals containing phosphates, NaOH , silicates, Na and Potassium Salts. These chemicals are found in most commercial degreasers and cleaners; therefore, only the self-clean feature should be used.

⚠ CAUTION: The catalytic converter can be cleaned with TurboChef® oven cleaner and rinsed thoroughly with distilled water. Let the catalytic converter air dry before reinstalling. If TurboChef oven cleaner is not available, DO NOT use a substitute. Use distilled water only.

Exhaust Blower

The exhaust blower is located in the bottom rear of the single wall oven. It's purpose is to vent the hot air from the electrical compartment.

Vent Catalyst

In addition to the main catalytic converter, the Speedcook oven contains an additional catalyst in the vent tube path. This catalyst further assists in the breakdown of grease and particulate matter before the excess air enters the atmosphere.

*This page intentionally
left blank.*

Section 6

Troubleshooting

Overview of Troubleshooting

This section contains information pertinent to troubleshooting issues with the TurboChef® Residential Double Wall or Single Wall ovens.

It is divided into two main sections:

- Error Screens
- Component Testing and Troubleshooting

Within these sections, some procedures are relevant only to specific oven models.

The variables are:

- Double Wall Oven: If the procedure is specific to a double-wall oven, it will be in regards to the lower oven, as the top oven is functionally identical to the single-wall oven.
- Single Wall Oven: No procedure will be specific only to a single wall oven, as it is functionally identical to the top oven of the double-wall.
- Gen 1: The procedure will apply only to ovens with a serial number mask of TDO#####. Note that all single-wall ovens are Gen 2.
- Gen 2: The procedure will apply only to ovens with a serial number mask of TDO2D##### or TSO2D#####.
- No designation: If there is no designation on a procedure, then it applies to all oven types and configurations.

For more information on part descriptions and functions, see *Section 5: Oven Systems*. For information on removing parts, see the Appendix.

Error Screens

Below are the descriptions and possible causes of the different error screens:

- Oven Door Open (Gen 1)
- Oven Door Open (Gen 2)
- Cooling Fan Failure (Gen 1)
- Cooling Fan Failure (Gen 2)
- Temperature Control Failure
- Magnetron Failure
- Blower Failure
- Oven Over Temperature

Oven Door Open (Gen 1)

When the door is closed, two cams are rotated by the door's actuators to close the left and right interlock N.O. switches. These switches are wired in series between P7-5 and P8-5 on the control board to monitor the door's position. If this circuit is broken during the preheat or cooking cycle, or if the monitor switch, P7-15 and P8-4, fails, this error screen is displayed.

Possible causes:

- The door is open
- The door switch assemblies require adjustment
- Faulty left and/or right lock motor assembly
- The switch is not closing because the left and/or right lock motor assembly has not been installed correctly
- Faulty wiring
- Faulty control board
- Failed monitor switch

Possible components to be replaced:

- Left lock motor assembly
- Right lock motor assembly

Troubleshooting:

1. Verify whether the door is fully closed.
2. Verify the hinges on the door have been fully inserted (see page 5.2).
3. Test pins P8-4 and P7-15 for continuity through the monitor switch.
4. Check to see if the hinges or actuators are bent.
5. Check to see if one of the door cams are over-rotated, if so, correct or replace it.
6. Adjust the door switches.

Note: Figure 6.1 shows the adjustable version of the door switch assembly. Older versions were not adjustable. If an oven has un-adjustable switch assemblies, contact TurboChef to order the adjustable door switch assemblies.

- Remove the door switch covers, located on the right and left side of the Speedcook oven.
- Mark the original position of the adjustment slide for reference.

- With the door fully closed, loosen the door switch's adjustment screw(s).
- With a screwdriver, adjust the switches at the triangle adjustment slot.
- When the door open message disappears, move the slide an additional 1/32 in (.8 mm) and tighten the adjustment screw(s).
- Open and close the door to ensure that the open door message appears only when the door is open.

NOTE: If switches were adjusted or replaced, you must perform a microwave leakage test (see page 5.4).

7. If adjusting the switches does not remove the Door Open message, verify the switches are operating correctly. If not, replace the faulty switch(es). If they are, replace the control board.

Oven Door Open (Gen 2)

When the door is closed, the two cams in the switch assemblies are rotated by the door actuators. These cams then actuate the door sensing switches. These switches are wired independently to the control board; the left J15-7 and J15-8 and the right J15-9 and J15-10. If either switch is open, the error screen is displayed.

The monitor switch can also cause this error message; check pins J15-6 and J15-5 for continuity. All other causes are covered in the Gen 1 listing, above.

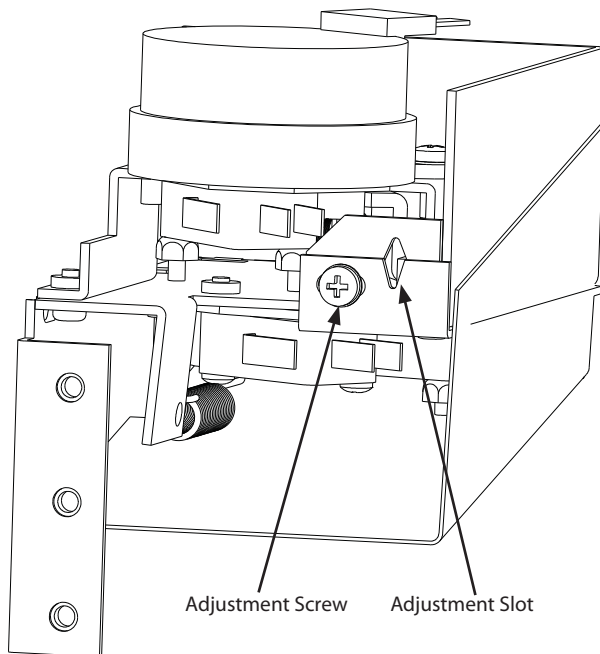

Figure 6.1: Door Switch Assembly

Cooling Fan Failure (Gen 1)

A motion sensor on each of the two cooling fans sends voltage pulses of 5 VDC to the control board. These pulses are created when a magnet on the cooling fan oscillates around the sensor. If one of the fans is not spinning for any reason, its magnet will not oscillate and the fan's motion sensor will not operate, causing this error screen to be displayed.

Possible causes:

- Loose wire connection
- Faulty cooling motor
- Faulty motion sensor
- Faulty CookWheel mechanical switch

Possible components to be replaced:

- Cooling motor assembly

See pages 6.7-6.9 for further troubleshooting.

Cooling Fan Failure (Gen 2)

The Gen 2 oven upper cooling fan is identical to the one in the Gen 1 oven; however, the single wall oven also includes a sail switch near the bottom exhaust fan to check fan operation. If this switch fails to close, an error will be displayed. All other causes are covered in Gen 1 listing, above. See pages 6.7-6.9 for further troubleshooting.

Temperature Control Failure

The control board monitors cook cavity temperature with the use of one RTD in each oven. If the control board loses communication with an RTD, this error screen is displayed. See page 6.6 for the RTD testing procedure.

Possible causes:

- Faulty wiring/loose connections
- Faulty upper or lower RTD
- Faulty control board.

Possible components to be replaced:

- RTD (upper or lower oven - both should be tested)
- Control board

Magnetron Failure

A current transformer located on the control board monitors the current draw of the microwave system. The oven uses two separate magnetron circuits, each drawing approximately 8-9 amps. If the control board senses 0 amps, this error screen is displayed.

Possible causes:

- Faulty K3 or K4 relay (Gen 1) or relay 2 or 3 (Gen 2; the entire relay board must be replaced)
- Faulty left or right high-voltage transformer
- Faulty left or right high-voltage capacitor
- Faulty left or right high-voltage diode
- Faulty left or right magnetron
- Faulty 20-amp fuse (Gen 2: located on relay board as F1 fuse)
- Faulty wiring
- Faulty control board
- Faulty left or right magnetron thermostat

Possible components to be replaced:

- K3 relay (Gen 1) or relay 2 or 3 (Gen 2; the entire relay board must be replaced)
- K4 relay (Gen 1) or relay 2 or 3 (Gen 2; the entire relay board must be replaced)
- High voltage transformer
- High voltage capacitor
- High-voltage diode
- Magnetron
- 20 amp fuse (Gen 2: located on relay board as F1 fuse)
- Control board
- Left or right magnetron thermostat

Magnetron Failure Troubleshooting

1. Pull the oven 11" (280 mm) from the cabinet and remove the top front cover.
2. Place the oven in Installer Setup mode (page 4.4).
3. Place a water load in the cook cavity.

⚠ DANGER: DO NOT touch or attempt to measure the magnetrons, HV transformers, capacitors, or any component within the microwave circuit while the magnetrons are running. Lethal voltage will be present.

4. Turn the magnetrons on and measure for 15-19 amps around the wire in the current transformer loop on the control board.

5. Turn the magnetrons off. Depending on the measurement, follow the below steps.

If 15-19 amps are present, verify the magnetron cooling fans are running whenever the magnetrons are running. The thermostats can cause the magnetrons to shut down and reset when cool.

If 8.5-10 amps are present,

1. Check relay operation. For Gen 1, check the control voltage from the control board at P8-13 + P8-5, and at P8-14 + P8-5. For Gen 2, visually check relays 2 and 3 for operation. If they operate correctly, check the HV outputs to each transformer at terminals RBJ-4 + RBJ-5.
2. Isolate the left and right magnetron circuits and retest. For Gen 1 ovens, remove the brown lead to the transformer. For Gen 2 ovens, remove either RBJ-4 or RBJ-5.

If 0 amps are present,

1. Ensure power is reaching the oven from the wall.
2. Check the 20-amp fuse.
3. Check for incoming voltage at each transformer when the magnetrons are energized. For Gen 1, test voltage from the relays at the transformer. For Gen 2, 208 or 240 VAC must be between the blue wire at the CT coil (CT1-B) and either terminal RBJ-5 (right) or RBJ-4 (left) on the relay board.

Blower Failure

The control board sends voltage to the blower motor speed controller (BMSC) to activate the blowers. If both blowers successfully activate, a signal is sent back to the control board to verify the system is functioning normally. If that signal is not sent back to the control board, this error screen is displayed.

Possible causes:

- BMSC (blower motor speed control)
- Blower motors
- Faulty control board
- Faulty wiring
- Faulty relay board (Gen 2 only)

Possible components to be replaced:

- BMSC
- Blower motors
- Control board
- Relay board (Gen 2 only)

Blower Failure Troubleshooting

1. Confirm the motor is turning freely. Check for obstructions.
2. Test the upper motor for 0-10 VDC incoming on
 - Gen 1: P10-1 and P7-17 (control board)
 - Gen 2: RBJ22-5 and RBJ22-8 (relay board)
3. Test the lower motor for 0-10 VDC incoming on
 - Gen 1: P10-2 and P7-19 (control board)
 - Gen 2: RBJ22-6 and RBJ22-8 (relay board)
4. Check for line voltage to the motor controller (power is supplied from the EMI filter).
5. Ohm-test the motors for 5.9-7.3 ohms.

Oven Over Temperature

To prevent temperature from running away during normal oven operation, each oven cavity is monitored by a thermostat (270°F [132°C] switch for Speedcook cavity and 280°F [138°C] for the lower oven cavity in double wall ovens). In both the single and double wall oven, the switch(es) are wired to the control board through P7-18 and P8-6 (Gen 1) or pins J15-18 and J15-19 (Gen 2). If the ambient temperature near these thermostats exceeds the temperatures given above, this error screen is displayed. The thermostats are self resetting; however, the oven is disabled until both switches are closed.

Possible causes:

- Overheated oven
- Faulty wiring
- Faulty thermostat switch
- Faulty control board

Component Testing and Troubleshooting

This section contains the following sub-sections:

- Control system
- Halogen light system
- Cooling system
- Air impingement system
- Microwave system
- Heating system, Speedcook oven
- Heating system, lower oven

Control System

This section contains testing and troubleshooting procedures for the following components:

- Clock assembly
- Control board
- CookWheel control (Speedcook oven)
- EMI filter
- Oven mode switch (lower oven)
- Power supply, 12 VDC
- Power supply, 24 VDC
- RTD
- Transformer, clock, 12 VAC (located on relay board on Gen 2 ovens)

Clock Assembly

1. Access the upper electrical compartment.
2. Apply voltmeter probes to pins 1 and 5 on the clock assembly.
3. If approximately 12 VAC is present, the clock assembly is faulty and needs to be replaced. If no voltage is present, test the 12 VAC transformer.

Control Board

1. Verify all wiring is secure and correctly connected. See section 7 for wiring schematics.
2. Ensure the SD card is in the unlocked position (always remove power from the oven before removing the SD card).
3. Troubleshoot other oven components related to the failure if applicable.
4. If required, replace the control board.
5. Fill out the tag supplied with the replacement board (identifying the issue) and return it to TurboChef with the bad control board.

CookWheel Control (Speedcook Oven)

1. Access the upper electrical compartment.
2. Verify the CookWheel's switch closes and opens normally. This test assumes that the CookWheel is receiving voltage from the 15-amp fuse (see page A.15 for Gen 1 location, page A.19 for Gen 2 location). If no voltage is present, then the lights, screens, clock, etc. will not function.
3. Disconnect the N.O. wire from the terminal.

4. To test the switch in the open position, turn the CookWheel to the off position.
5. Apply the probes of the voltmeter to the now-exposed CookWheel N.O. terminal and ground. The voltage reading should be 0 VAC.
 - If voltage is present, the CookWheel control/switch is stuck closed. Replace the CookWheel.
 - If no voltage is present, the CookWheel is functioning properly in the open position.
6. To test the switch in the closed position, turn the CookWheel to the Bake position.
7. Apply the probes of the voltmeter to the same CookWheel N.O terminal and ground. The voltage reading should be 120 VAC.
 - If no voltage is present, the oven mode switch is stuck open and needs to be replaced.
 - If 120 VAC is present, the CookWheel is functioning properly in the closed position.

Power Supply, 12 VDC

1. Test the voltage.
 - To test the upper light voltage. Test for 12 VDC at pins 1 and 4 on the power supply.
 - To test for lower light voltage. Test for 12 VDC at pins 2 and 3 on the power supply.
2. If the upper or lower lights are not receiving the correct voltage, test for 120 VAC at the blue L2 and white neutral wire terminals.
 - If 120 VAC is present at the terminals, disconnect the load wires and recheck for 12 VDC output. Investigate shorted wiring before replacing the power supply.
 - If 120 VAC is not present at the terminals, check the 15-amp fuse/fuse block (Gen 1) or fuse output RBJ-6 on the relay board (Gen 2).

EMI Filter

1. Disconnect power before ohm testing.
2. Check for continuity from Line to Load tabs (both legs). Replace if open.
3. Check for open circuit between L1 and L2 tabs (L1 to case, L2 to case). Replace if shorted.

Oven Mode Switch (Lower Oven)

1. Access the lower electrical compartment by removing the oven frame as shown on page A.10.
2. Verify the oven mode dial switch closes and opens normally. This test assumes that the oven mode dial is receiving voltage from the 15-amp fuse. If no voltage is present the lights, LCD screens, clock, etc. will not function.
3. Disconnect the N.O. blue wire from terminal 2.
4. Test the switch while it is open, turn the oven mode dial to the off position.
5. Apply the probes of the voltmeter to the now-exposed oven mode dial N.O. terminal 2 and ground. The voltage reading should be 0 VAC.
 - If voltage is present, the oven mode switch is stuck closed. Replace the oven mode switch.
 - If no voltage is present, the oven mode switch is functioning properly in the open position.

Power Supply, 24 VDC

1. Test the voltage.
 - For Gen 1, verify voltage to the power supply from the 15-amp fuse.
 - For Gen 2, verify voltage to the power supply from terminal RBJ-6 on the relay board.
2. Test for 120 VAC at the terminals at the thick blue and white wires on the left.
 - If 120 VAC is not present, then probably no oven functions are operating. Ensure the 15-amp fuse is operating correctly.
 - If 120 VAC is present, continue to step 3.
3. Test for 24 VDC at the terminals at the thick red and black wires on the right. If 24 VDC is not present, disconnect the load wires and recheck for 24 VDC output. Investigate shorted wiring before replacing the power supply.

°F	0°	+20°	+40°	+60°	+80°	+100°	+120°	+140°	+160°	+180°	+200°
0°	90.03 Ω	97.39 Ω	101.74 Ω	106.07 Ω	110.38 Ω	114.68 Ω	118.97 Ω	123.24 Ω	127.50 Ω	131.74 Ω	135.97 Ω
+200°	135.94 Ω	140.18 Ω	144.38 Ω	148.57 Ω	152.74 Ω	159.90 Ω	161.04 Ω	165.17 Ω	169.29 Ω	173.39 Ω	177.47 Ω
+400°	177.47 Ω	181.54 Ω	185.60 Ω	189.64 Ω	193.67 Ω	197.69 Ω	201.69 Ω	205.67 Ω	209.64 Ω	213.60 Ω	217.54 Ω
+600°	217.54 Ω	221.47 Ω	225.38 Ω	229.28 Ω	233.17 Ω	237.04 Ω	240.90 Ω	244.74 Ω	248.57 Ω	252.38 Ω	256.18 Ω

Figure 6.2: Temperature-Ohm Chart (Fahrenheit)

°C	0°	+10°	+20°	+30°	+40°	+50°	+60°	+70°	+80°	+90°	+100°
0°	100.00 Ω	103.90 Ω	107.79 Ω	111.67 Ω	115.54 Ω	119.40 Ω	123.24 Ω	127.07 Ω	130.89 Ω	134.70 Ω	138.50 Ω
+100°	138.50 Ω	142.29 Ω	146.06 Ω	149.82 Ω	153.58 Ω	157.31 Ω	161.04 Ω	164.76 Ω	168.46 Ω	172.16 Ω	175.84 Ω
+200°	175.84 Ω	175.91 Ω	183.17 Ω	186.82 Ω	190.45 Ω	194.07 Ω	197.69 Ω	201.29 Ω	204.88 Ω	208.45 Ω	212.02 Ω
+300°	212.02 Ω	215.57 Ω	219.12 Ω	222.65 Ω	226.17 Ω	229.67 Ω	233.17 Ω	236.65 Ω	240.13 Ω	243.59 Ω	247.04 Ω

Figure 6.3: Temperature-Ohm Chart (Celsius)

RTD

The procedures below outline troubleshooting procedures for the RTD in the Gen 1, Gen 2, and Single Wall Oven.

Troubleshooting the RTD (Gen 1),

1. Turn oven power off and pull the oven 11" (280 mm) out of the cabinet.
2. Remove the top front cover.
3. Remove P9 from the control board and test the lower RTD on pins P9-5 and P9-6 for 109 ohms at 75°F (24°C).
4. Remove P10 from the board and test the upper sensor on pins P10-19 and P10-20 for 109 ohms at 75°F (24°C).
5. If 109 ohms (or appropriate value) are present, replace the control board and retest. If not, replace the appropriate RTD and retest.

Troubleshooting the RTD (Gen 2),

1. Turn oven power off and pull the oven 11" (280 mm) out of the cabinet.
2. Remove the top front cover.
3. Remove J16 from the control board and test the lower RTD on pins J16-8 and J16-9 for 109 ohms at 75°F (24°C).
4. Remove J15 from the control board and test the upper RTD on pins J15-20 and J15-21 for 109 ohms at 75°F (24°C).
5. If 109 ohms (or appropriate value) are present, replace the control board and retest. If not, replace the appropriate RTD and retest.

Troubleshooting the RTD (Single Wall Oven),

1. Disconnect power from the oven.
2. Disconnect J15 from the control board.
3. Test the RTD on pins J15-20 and J15-21 for 109 ohms at 75°F (24°C).
4. If 109 ohms (or appropriate value) are present, replace the control board and retest. If not, replace the RTD and retest.

Transformer, Clock, 12 VAC (Gen 1)

1. Test for 12 VAC at the terminals at the two thin white wires.
 - If 12 VAC is present, the transformer is functioning properly.
 - If no voltage is present, continue to step 2.
2. Test for 120 VAC at the terminals of the thick white and blue wire.
 - If 120 VAC is present, the transformer is faulty and needs to be replaced.
 - If no voltage is present, investigate the 15 amp fuse/fuse block.

Transformer, Clock, 12 VAC (Gen 2)

1. Test for 12 VAC at terminals RBJ18-1 and RBJ18-2 on the relay board.
 - If 12 VAC is present, the transformer is functioning properly.
 - If no voltage is present, continue to step 2.
2. Test for 120 VAC at the terminals at the thick white and blue wire.

- If 120 VAC is present, the transformer is faulty and the relay board needs to be replaced.
- If no voltage is present, investigate the 15 amp fuse (F2) on the relay board.

Halogen Light System

This section contains information on the following topics:

- Light switch, control panel
- Light switch, Speedcook oven
- One Speedcook oven light is out
- Both Speedcook oven lights are out
- Both Speedcook oven and both lower oven lights are out (double-wall oven)

Light Switch, Control Panel (Manual)

1. Access the control panel light switch through the upper electrical compartment.
2. Disconnect the light switch from the harness. Separate the harness at the connection between the blue/black wires.
3. Apply the probes of the ohmmeter to the two black wires attached to the switch.
4. Check for continuity through the switch by manually engaging the switch.

Light Switch, Speedcook Oven (Door-Actuated)

1. Access the light switch by removing the left lock motor assembly.
2. Disconnect wiring leading to the light switch.
3. Apply the probes of the ohmmeter to the electrical connector still attached to the assembly, pins 2 and 6 (purple wires).
4. Check for continuity through the switch by manually engaging the switch.

One Speedcook Oven Light is Out

 **CAUTION:** DO NOT touch the bulb with bare fingers; rather, use gloves, cloth or tissue to hold the bulb. If the bulb is accidentally touched, clean it with isopropyl alcohol before applying power.

1. Replace the bulb (see page 5.5).
2. If replacing the halogen bulb did not fix the problem, access the rear of the halogen light assembly and disconnect the two green wires at the wire connectors.
3. Apply the probes of the voltmeter to the two green wires leading from the oven. The voltage reading should be 12 VDC.
 - If 12 VDC is present, the halogen light assembly is faulty and needs to be replaced.
 - If 12 VDC is not present, check all wires and connections in the halogen light system.

Both Speedcook Oven Lights are Out

When the control panel switch is pressed and the oven door is closed, test the control panel switch. When the oven door is opened and the control panel switch is not pressed, test the light switch/left lock motor assembly.

Both Speedcook Oven and Both Lower Oven Lights are Out (Double Wall Oven)

Test the 12 VDC power supply (see page 6.5 for troubleshooting).

Cooling System

This section contains information on the following topics:

- Cooling fan overview (Gen 1)
- Cooling Fan Overview (Gen 2)
- Troubleshooting Cooling Fans (Gen 1)
- Troubleshooting Cooling Fans (Gen 2)

Cooling Fan Overview (Gen 1)

A motion sensor on each of the two cooling fans sends voltage pulses of 5 VDC to the control board. If one of the cooling fans is not spinning, a cooling fan error will be displayed.

Components that activate the cooling fans are:

- CookWheel (Speedcook oven)
- Mode knob (lower oven)
- 140°F (60°C) snap switch (Speedcook oven)
- 160°F (71°C) snap switch (lower oven)

Possible components to be replaced:

- Cooling fan assembly
- F3 5 amp fuse (Gen 1)
- CookWheel mechanical switch (Speedcook oven)
- Cook mode mechanical switch (lower oven)
- 140°F (60°C) snap switch (Speedcook oven)
- 160°F (71°C) snap switch (lower oven)
- Control board
- K9 Relay

Cooling Fan Overview (Gen 2)

The Gen 2 double wall oven has two cooling fans: one for the top oven and one for the bottom oven. The single wall oven also has two cooling fans, but the lower cooling fan has a sail switch instead of a hall effect motion sensor to check fan operation. If the sail switch fails to close, a cooling fan error will be displayed.

Components that activate the cooling fans are:

- CookWheel (Speedcook oven)
- Mode knob (lower double wall oven)
- 140°F (60°C) snap switch (Speedcook oven)
- 160°F (71°C) snap switch (lower oven)
- Control board when the Speedcook cavity temperature is above 350°F (177°C) and the Cook-Wheel is in the off position.
- Relay board

NOTE: If the CookWheel is set to “off,” the cooling fans will stay on for an additional 2 minutes after the cook cavity temperature recedes below 350°F (177°C). If the CookWheel is set to any other mode, the fans will remain on.

NOTE: If the Speedcook cook cavity temperature is above 350°F (177°C) or either snap switch has closed, the cooling fans will remain on even if the CookWheel is in the off mode.

Troubleshooting Cooling Fans (Gen 1)

If a cooling fan failure message is displayed, test the top and bottom motor assemblies by performing the following steps:

1. Press the Cancel button on the top display to clear the cooling fan error message.
2. Turn the CookWheel to the off position. The cooling fans should turn off (unless one of the snap switches has closed). The magnetron fans will continue to operate for two minutes.
3. Turn the CookWheel to favorites or the lower cook mode knob to bake. You should hear the fans running and also feel a slight amount of air being discharged from the bottom of the oven.
4. If the fans are not operating, remove the oven from the cabinet approximately 11” (279 mm) and remove the top front panel.
5. Check the motion sensor signal outputs to the control board by applying multimeter probes to P9-7 and P9-17 for the bottom cooling fan and P8-10 and P7-12 for the top cooling fan.
 - If 2.5 VDC is present, the fan is functioning normally. If both cooling fans register 2.5 VDC while the cooling fan failure message is displayed, the control board is faulty and needs to be replaced.
 - If 5 VDC or 0 VDC is present, either a cooling fan motion sensor is faulty or a motor assembly is not functioning and needs to be tested.
6. If neither fan is operating, check the 5 amp fuse located on the right magnetron cover in the top oven electrical compartment. If the fuse has not blown, Check the operation of the Cookwheel and the K9 relay. If the fuse has blown, continue to step 7 before replacing fuse.
7. Troubleshoot the following potential reasons as to why the fuse was blown:
 - Does the control board reset when the CookWheel is in the off mode?
 - Was/is there a supply power surge?
 - Is the cooling fan faulty?
 - Is any wiring faulty?
 - Is the control board faulty?
8. Remove the 5-amp fuse, turn the Cookwheel to off, and check the single side terminal of the fuse block for 120 VAC.
9. If voltage is present, check the control board for 24 VDC at pins P7-3 and P8-16 (K1-A), P7-3 and P8-15 (K1-B), P8-9 and P7-8 (K8). If 24 VDC is present on one or more of these test points, replace the control board. If the 5-amp fuse was blown and no 24 VDC found, check the K1 and K8 relays for shorted closed condition.
10. If after performing the above steps the cooling fans are still not functioning, completely remove the oven from the cabinet for access.

11. Turn the CookWheel to favorites.
12. Test the cooling fan motor assemblies by applying voltmeter probes to the terminals on the motor. The voltage reading should be 120 VAC.
 - If 120 VAC is present and the fan is not functioning, replace the cooling fan.
 - If voltage is not detected, test the source of the voltage at the cookwheel mechanical switch (top oven), mode mechanical switch (bottom oven), 15 amp fuse, and the circuit wiring for breaks.

Troubleshooting Cooling Fans (Gen 2)

If a cooling fan failure message is displayed, test the top and bottom cooling fan motor assemblies:

1. Turn the CookWheel to off to clear the cooling fan error message. The cooling fans should turn off after two minutes (unless one of the snap switches has closed or the upper cook cavity is above 350°F [177°C]).
2. Turn the CookWheel to favorites or the lower mode knob to bake (double wall oven). You should hear the fans running and also feel a slight amount of air being discharged from the bottom of the oven.

NOTE: The cooling fan error message will display again after the CookWheel has been turned to favorites for five minutes. If the CookWheel is not turned to favorites after the cooling fan error message displays, the cooling fans will turn off after approximately 2 minutes.

3. If the fans are not operating, remove the oven from the cabinet approximately 11" (279 mm) and remove the top front panel.
4. Check the motion sensor signal outputs to the control board:
 - For the double wall oven, apply multimeter probes to J15-16 and J15-17 for the top oven cooling fan and J16-2 and J16-3 for the bottom oven cooling fan. If the fans are on, 2.5 VDC should be present. A reading of 0.0 VDC or 5.0 VDC means the cooling fans are not rotating. Check sensor wiring and cooling fan for operation.

- For the single wall oven, turn the CookWheel to favorites and test pins J16-2 and J16-3 for 0 VDC at the control board. If 0 VDC is present, then the sail switch is activated, indicating the lower fan is turning. If approximately 4.5 VDC is present, either the fan is not turning or the switch is stuck. Remove the fan to determine the faulty part.

NOTE: Single Wall Ovens do not use a motion sensor on the bottom fan.

5. If both fans are functioning and sending the correct voltage to the control board, but a cooling fan error is displayed, replace the control board.
6. If the cooling fans do not operate properly, check the following components:
 - Cooling fan assembly (top and bottom)
 - CookWheel switch (Speedcook oven)
 - Mode mechanical switch (bottom oven)
 - 140°F (60°C) snap switch (Speedcook oven)
 - 160°F (71°C) snap switch (lower oven)
 - Sail switch (single wall oven only)
 - Control board
 - Relay board

Air Impingement System

This section contains information on:

- Blower motors, Speedcook oven
- Convection fan, lower oven

Blower Motors, Speedcook Oven

1. Access the Speedcook oven blower motors (see pages A.24 and A.26).
2. To test the blower motors, take an ohm reading of each motor. Disconnect the output from the motor controller (BMSC) and check the ohms from phase to phase (red to black, black to white, and red to white). All the readings must be between 5.9 and 7.3 ohms. If any of these readings are different, replace the motor.
 - Check the resistance through the meter leads by touching them together. Subtract this number from the reading of the motor

to ensure accuracy. If either motor does not register between 5.9 and 7.3 ohms, replace that motor and retest the oven.

3. Verify 0-10 VDC is being sent to the motor controller.
 - For Gen 1 ovens, check the control board on P10-1 and ground for upper, check P10-2 and ground for lower.
 - For Gen 2 ovens, check the relay board terminals RBJ22-5 and RBJ22-3 for upper, check RBJ22-6 and RBJ22-4 for lower.
 - If no voltage is present, replace the control board.
4. Verify 208/240 input to motor controller by measuring the brown and blue wires on the 3-pin connector.
5. If all the above tests are verified, replace the motor controller.

Convection Fan, Lower Oven

1. Turn the lower oven mode dial to Convection Bake to activate the convection fan. If the fan does not activate immediately, turn the lower oven off and access the convection fan motor inside the oven (see page A.28).

 **CAUTION:** Voltage on terminals could cause injury. Proceed with caution.

2. Apply the voltmeter probes to the convection fan motor's terminals.
 - If 120 VAC is not present, investigate the oven mode dial for a loose wire to terminal 3 or a faulty switch.
 - If 120 VAC is present, the convection fan motor is faulty and needs to be replaced.

Microwave System

This section contains information on the following topics:

- Testing a capacitor
- Testing a high-voltage diode
- Testing a high-voltage transformer
- Testing a magnetron for open/shorted filament

See page 6.2 for additional troubleshooting for a magnetron failure message.

Testing a Capacitor

 **DANGER:** Never attempt any measurement of the capacitors while they are enabled. Lethal voltage will be present. Measure only in compliance with these procedures.

To test for an open or shorted capacitor:

1. Disconnect the oven from the power source.
2. Fully discharge the capacitor.
3. Isolate the capacitor from the circuit.
4. Check for an open or shorted capacitor by placing ohmmeter leads between the capacitor terminals:
 - Inconsistent readings = capacitor not shorted or open.
 - Constant infinite resistance = capacitor open
 - Constant very low resistance = capacitor shorted
5. If the capacitor is not open or shorted, set the meter to measure microfarad capacitance and again place the leads between the capacitor terminals. The meter reading should equal the label value, plus or minus 10%. If not, replace the capacitor.

To test for capacitor terminals that may be shorted to casing:

1. Disconnect the oven from the power source.
2. Fully discharge the capacitor.
3. Isolate the capacitor from the circuit.
4. Place one meter lead on a terminal and the other on the metal jacket of the capacitor. Infinite resistance must be seen. Any other reading means the capacitor should be replaced.

Testing a High-Voltage Diode

 **DANGER:** Before replacing the high-voltage diode, ensure the oven is removed from any power source. Replacing this component while the oven is plugged in can result in serious injury or death.

 **DANGER:** Never attempt to measure high voltage directly. Death or serious injury could result.

1. Disconnect the oven from the power source.
2. Fully discharge the capacitors.

3. Disconnect the diode from the circuit.
4. Set the voltage meter to DC voltage and connect it in series with the diode and a 9-volt battery.
5. Connect one meter lead to one side of a 9-volt battery and the other lead to one side of the diode.
6. Connect the other side of the 9-volt battery to the other side of the diode. DC voltage should only be present on the meter in one direction.
7. Switch the meter leads on the diode, which will cause the opposite reading to be visible. voltage between 5-7 VDC should be present in only one direction and 0-0.1 VDC in the other direction, depending on the battery voltage.

Testing a High-Voltage Transformer

⚠ DANGER: Before replacing the transformer, ensure the oven is removed from any power source. Replacing this component while the oven is plugged in can result in serious injury or death.

⚠ DANGER: Never attempt to measure the secondary voltage values of the transformers when they are enabled. Lethal voltage will be present.

1. Disconnect the power source and discharge the high-voltage capacitors.
2. Disconnect all the wires on the transformer.
3. Use an ohmmeter to check primary winding, secondary winding, and filament.
 - Primary Side
 - 240 VAC: Taps 1&3 = 1.4 Ω
 - 208 VAC: Taps 1&2 = 1.2 Ω
 - Secondary Side
 - 240 & 208 VAC: Tap 4&Casing = 70.1 Ω
 - Filament
 - 240 & 208 VAC: Red Wires = 0.1 Ω

Testing a Magnetron for an Open/Shorted Filament

⚠ DANGER: The only safe way to test a magnetron is by a resistance test of its filament. Never attempt to measure the magnetron using any other method while the microwave system is on. Death or serious injury could occur.

1. Disconnect the power source and discharge the high-voltage capacitors.
2. Isolate the magnetron from the circuit by removing the wires from terminals F and FA.
3. An ohmmeter connected between the filament terminals (F, FA) should indicate a reading of less than 1 ohm.
4. A continuity check between either filament terminal and the magnetron chassis should indicate an infinite resistance (open).

⚠ CAUTION: Be careful to not allow debris into the waveguides when servicing the magnetrons.

Heating System, Speedcook Oven

The Speedcook oven heating elements require 208-240 VAC to operate.

NOTE: The elements are voltage specific and cannot operate properly without the correct voltage applied. Confirm incoming voltage matches the oven's specifications (listed on the serial plate behind the oven door).

When the CookWheel is turned to any of the seven cooking cycles (except Favorites), the control board sends voltage to activate the relays, which supply power to the heating elements. L1 voltage for the two primary elements are supplied through the K1 SSR and the L1 voltage for the preheat element is supplied through the K8 relay (Gen 1) or preheat relay 14 (Gen 2 relay board). The L2 voltage for all three elements is supplied from the N.O. contact on the K9 relay.

If the oven is not heating normally, see the below troubleshooting options and use the one that best describes the situation.

This section contains information on the following topics:

- Heater element, Speedcook oven
- No heat
- Oven is heating up very slowly
- Testing for control voltage to the K1 SSR
- Testing for control voltage to the K8 relay (Gen 1)
- Testing relay 14, preheat (Gen 2)
- Testing for a K9 relay that is stuck open
- Testing for a K1 SSR that is stuck open

Heater Element, Speedcook Oven

Remove the wire connections and apply the probes of an ohmmeter to each element's respective terminals. The resistance should register 23 ohms for a 240 VAC unit and 17.0 ohms for a 208 VAC unit. If extreme resistance (a variance above 10%) is detected the element is faulty and needs to be replaced. Ensure that the elements are at room temperature. The temperature of the elements will change the heater's resistance.

No Heat

1. Turn the CookWheel to Bake to activate the preheating process. The oven should immediately make an audible 'click' when the K9 relay closes. Wait 2-3 minutes and the oven should heat noticeably. If no heat is present, pull the oven out 11" (280 mm) to access the front half of the upper electrical compartment.
2. Check the high limit switch. Press the red button to reset the switch. If the oven is still not heating, verify L1 (brown wires) and L2 (blue wires) power is reaching the heater elements.
3. Turn the CookWheel to off, then disconnect the three top brown wires from the high limit switch and turn the CookWheel to Bake.
4. Apply the probes of the voltmeter to each of the exposed female wire terminals and to ground. If any of the terminals do not register 120 VAC, check the breaker for a partial or full trip.
5. If the high limit switch is functioning properly, apply one probe to any one of the exposed female wire terminals and keep it there. Apply the other probe to the three male terminals on the high limit switch in sequence. At least one of the three readings should register 240 VAC if the oven is heating (if this is the case, go to *Oven is Heating Up Very Slowly*, adjacent).
6. If none of the elements are receiving 240 VAC, test the K9 relay, then the K1 and K8 relays (Gen 1) or K1 and relay 14 on the relay board (Gen 2) to verify both are receiving control voltage from the control board.

Oven is Heating up Very Slowly

1. Turn the CookWheel to Bake to begin preheating. The oven should immediately make an audible 'click' when the K9 relay closes.
2. After 2-3 minutes, the oven should heat noticeably. If little heat is present, pull the oven 11" (280 mm) from the cabinet to access the front half of the upper electrical compartment.

NOTE: If the oven is heating, the K9 relay is functioning because it is the single source of L2 voltage to all three elements. Therefore, testing should begin with L1 voltage reaching the elements.

3. Turn the CookWheel to off, then disconnect the three top brown wires from the high limit switch.
4. Turn the CookWheel to Bake.
5. Apply one probe of the voltmeter to any one of the exposed female wire terminals and keep it there. Apply the other probe to the three male terminals on the high limit switch in sequence. At least one of the three readings should register 240 VAC if the oven is heating at all.
6. If either of the primary elements is not receiving 240 VAC, test the K1 SSR to verify it is receiving voltage from the control board to activate.
7. If the preheat element is not receiving 240 VAC:
 - Gen 1: Test the K8 relay for 24 VDC from the control board to activate.
 - Gen 2: Test relay 14 for 9 amps on the relay board at RBJ10 and RBJ11.

Testing for Control Voltage to the K1 SSR

 **DANGER:** A high-voltage capacitor is located near this relay. Contact with the high-voltage capacitor could result in serious injury or death.

1. Turn the CookWheel to Bake to begin the preheat cycle.
2. For Gen 1 ovens, apply the voltmeter probes to P7-3 and P8-15, then to P7-3 and P8-16 (on the control board). For Gen 2 ovens, apply the voltmeter probes to RBJ22-7 and RBJ22-1, RBJ22-7 and RBJ22-2 (on relay board). The voltage reading for each should be 24 VDC. If 24 VDC is present, the relay is receiving voltage.

Testing for Control Voltage to the K8 Relay (Gen 1)

⚠ DANGER: A high-voltage capacitor is located near this relay. Contact with the high-voltage capacitor could result in serious injury or death.

1. Turn the CookWheel to Bake to begin the preheat cycle.
2. Apply the probes of the voltmeter to P7 – 8 and P8 – 9 (on the control board). The voltage reading should be 24 VDC.
 - If 24 VDC is present, the relay is receiving voltage.
 - If either/both of the relays fail to receive voltage, replace the control board and test the oven. If both relays are receiving 24 VAC, pull the oven out of the cabinet to test the K9, K1, and K8 relays, as well as the heating elements.

Testing Relay 14 (Pre-Heat) Operation (Gen 2)

1. Turn the CookWheel to Bake to begin the preheat cycle.
2. Apply the amprobe to the wire on terminal RBJ11 and confirm a measurement of approximately 9 amps is present. If 0 amps is present, ensure the pre-heat element is not faulty by checking the L1 voltage at terminal RBJ-10 to ground and RBJ-11 to ground (of the relay board). If voltage is present, continue.

NOTE: L1 voltage enters the relay board from the high limit switch at terminal RBJ-10 and leaves through RBJ-11.

Testing for a K9 Relay that is Stuck Open

1. Disconnect the single blue L2 wire and the three blue L2 wires from the K9 relay.
2. Turn the CookWheel to Bake to activate the K9 relay; it should make an audible click if functional.

NOTE: The K9 relay uses 120 VAC to activate the coil.

3. Apply the probes of the multi-meter to the common and N.O. terminals of the K9 relay that are now exposed. They should register continuity with an ohms test. If they do not,

verify the relay is receiving voltage from the blue wires still attached to the relay in the upper-left corner.

4. If voltage is present, replace the relay and test the oven. If no voltage is present, investigate for broken wires.
5. If the K9 relay is functioning normally, test if both the K1 and K8 relays are stuck open.

Testing for a K1 SSR that is Stuck Open

⚠ DANGER: A high-voltage capacitor is located near this relay. Contact with the high-voltage capacitor could result in serious injury or death.

Before servicing:

- a) Remove power from the oven.
- b) Discharge the high-voltage capacitors.
- c) Disconnect the primary voltage wiring of the high-voltage transformers.

1. After completing safety instructions above, reconnect power to the oven and turn the CookWheel to Bake.
2. The solid state relay is unable to be checked with an ohm test for continuity. Test for voltage through the switch by energizing the relay and leaving the brown wires connected, but pulled back enough to get a meter probe on the terminal.

⚠ CAUTION: DO NOT touch the meter leads together; this will cause the relay to short.

3. Set the meter to AC volts. A reading of 0 indicates a closed switch, and a reading of 208/240 indicates an open switch.
4. If both relays function normally, ohm out the heating elements and inspect the element's terminals.

Heating System, Lower Oven

The lower oven heating elements require 208-240 VAC to operate.

NOTE: The elements are voltage specific and cannot operate properly without the correct voltage applied. Confirm incoming voltage matches the oven's specifications (listed on the serial plate behind the oven door).

When the oven mode dial is turned to any of the seven cooking settings, the control board sends voltage to activate the relays, which supply power to the heating elements. L1 voltage for the bake and convection elements are supplied through the K11 SSR and the L1 voltage for the inner and outer broil elements is supplied through the K12 SSR. The L2 voltage for all three elements is supplied from the N.O. contact on the K13 relay.

If the oven is not heating normally, use the below troubleshooting option that best describes the situation.

This section contains information on the following topics:

- Lower oven heating element specifications
- No heat/slow to heat
- Testing for voltage to activate the K11 SSR
- Testing for voltage to activate the K12 SSR
- Testing for a K11 SSR that is stuck open
- Testing for a K12 SSR that is stuck open
- Testing for a K13 relay that is stuck open

Lower Oven Heating Element Specifications

Element	Amps at 208 volts	Amps at 240 volts	Ohms at 208 volts	Ohms at 240 volts
Bake	12.8	11.0	15.4	20.5
Convection	7.4	6.5	26.5	34.5
Inner broil	9.7	9.0	20.0	25.5
Outer broil	5.2	4.6	36.5	49.5

NOTE: If the bake or convection element are not activating, test for voltage to activate the K11 SSR. If the inner or outer broil elements are not activating, test for voltage to activate the K12 SSR.

No Heat/Slow to Heat

1. Turn the oven mode dial to Bake to begin preheating. The oven should immediately make an audible ‘click’ when the K13 relay closes.
2. After 2-3 minutes, the oven should heat noticeably. If no heat is present, pull the oven 11” (280 mm) from the cabinet to access the front half of the upper electrical compartment and the left and right lower electrical compartment access panels.
3. Using an amp-meter, test the brown wire on the left side of the upper electrical compartment.

NOTE: Line voltage is routed to the bottom oven from the terminal block in the upper electrical compartment. Brown, blue, and white wires will be traveling together on the far left side of the oven frame.

4. Verify that no amperage is being drawn to the elements. If any amperage is present, the K13 relay is functioning because it is the single source of L2 voltage to all three elements. Therefore, testing should begin with L1 voltage reaching the elements.
5. Check the high limit switch in the lower electrical compartment to see if it tripped. If so, press the red button to reset the switch.
6. Use the amp-meter on the brown wire in the upper electrical compartment again to verify the elements are drawing current.
7. If the oven is still not heating, test for which leg of power is not reaching the elements.
8. Turn the oven mode dial to off, then access the K13 relay behind the right side lower electrical compartment access panel.

Testing for Control Voltage to the K11 SSR

1. Turn the oven mode dial to Broil.
2. For Gen 1 ovens, apply the voltmeter probes to P9-2 and P9-15, then to P9-2 and P9-16 (of the control board). For Gen 2 ovens, apply voltmeter probes to terminals RBJ17-5 and RBJ17-2, then RBJ17-5 and RBJ17-1 (on the relay board). The voltage reading for each should be 24 VDC.

Testing for Control Voltage to the K12 SSR

1. Turn the oven mode dial to Bake to begin the preheat cycle.
2. For Gen 1 ovens, apply the voltmeter probes to P9-3 and P9-13, then to P9-3 and P9-14 (of the control board). For Gen 2 ovens, apply voltmeter probes to terminals RBJ17-5 and RBJ17-3, then RBJ17-5 and RBJ17-4 (on the relay board). The voltage reading for each should be 24 VDC.

Testing for a K11 SSR that is Stuck Open

1. Ensure the oven mode dial is in the off position.
2. Pull the insulated wire terminals back, but not off, to expose the terminal on all four brown wires of the relay.
3. Turn the oven mode dial to Bake to activate the relay.
4. Apply the probes of the multi-meter across the A1 and A2 terminals and B1 and B2 terminals individually. A 208/240 reading will show an open relay, 0 will show a closed relay.

Testing for a K12 SSR that is Stuck Open

1. Ensure the oven mode dial is in the off position.
2. Pull the insulated wire terminals back, but not off, to expose the terminal on all four brown wires of the relay.
3. Turn the oven mode dial to Broil to activate the relay.
4. Apply the probes of the multi-meter across the A1 and A2 terminals and B1 and B2 terminals individually. A 208/240 reading will show an open relay, 0 will show a closed relay.

Testing for a K13 Relay that is Stuck Open

1. Disconnect the two L2 blue wires from the K13 N.O. switch and the two L2 blue wires from the K13 common. Turn the oven mode dial to Bake to activate the K13 relay.
2. Apply the probes of the ohmmeter to the common and N.O. terminals of the K13 relay that are now exposed. They should register continuity. If they do not, verify the relay is receiving control voltage from the blue wires that are still attached to the relay in the upper left corner.
3. If control voltage is present, replace the relay and test the oven. If no voltage is present, investigate for broken wires.
4. If the K13 relay is receiving control voltage and is closing normally, L2 voltage is reaching the elements. The K11 and K12 solid state relays will probably not both short in the open state, so test the control board for control voltage reaching the K11 and K12 SSR.

*This page intentionally
left blank.*

Section 7

Oven Schematics

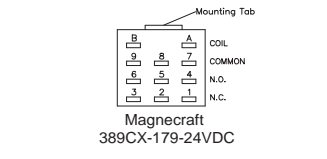
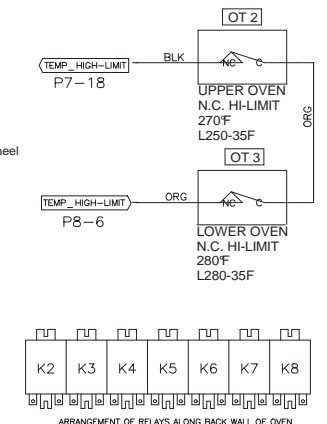
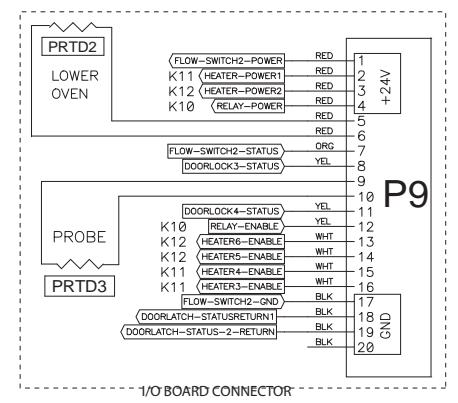
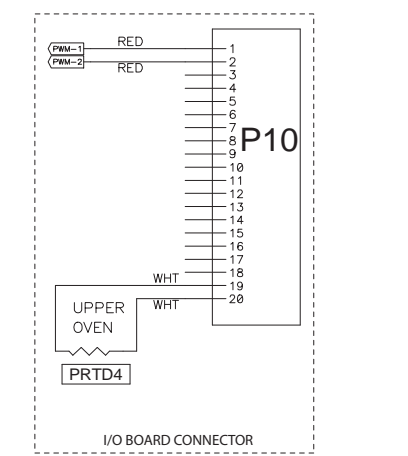
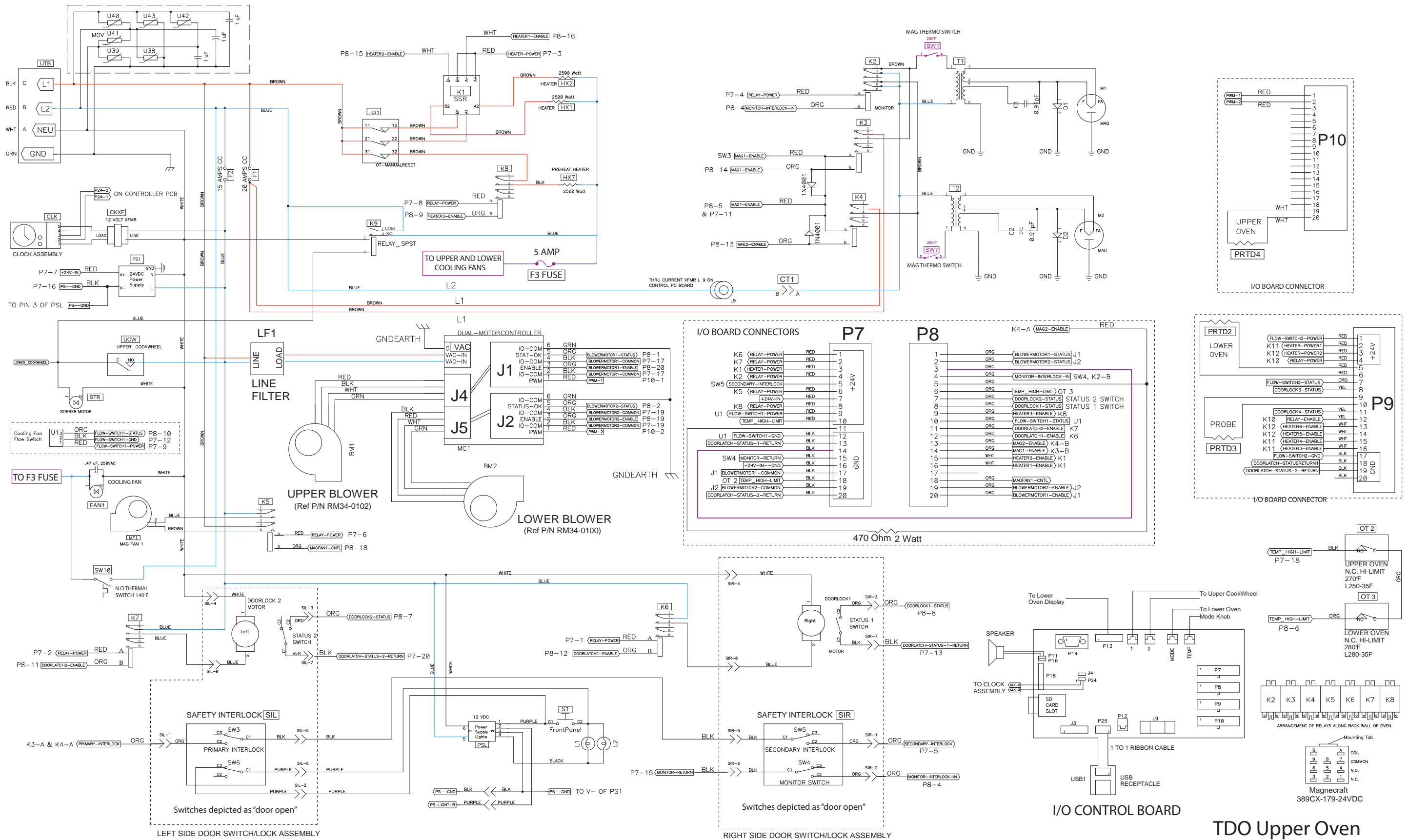

TDO Upper Oven (Generation 1)

7.2 OVEN SCHEMATICS

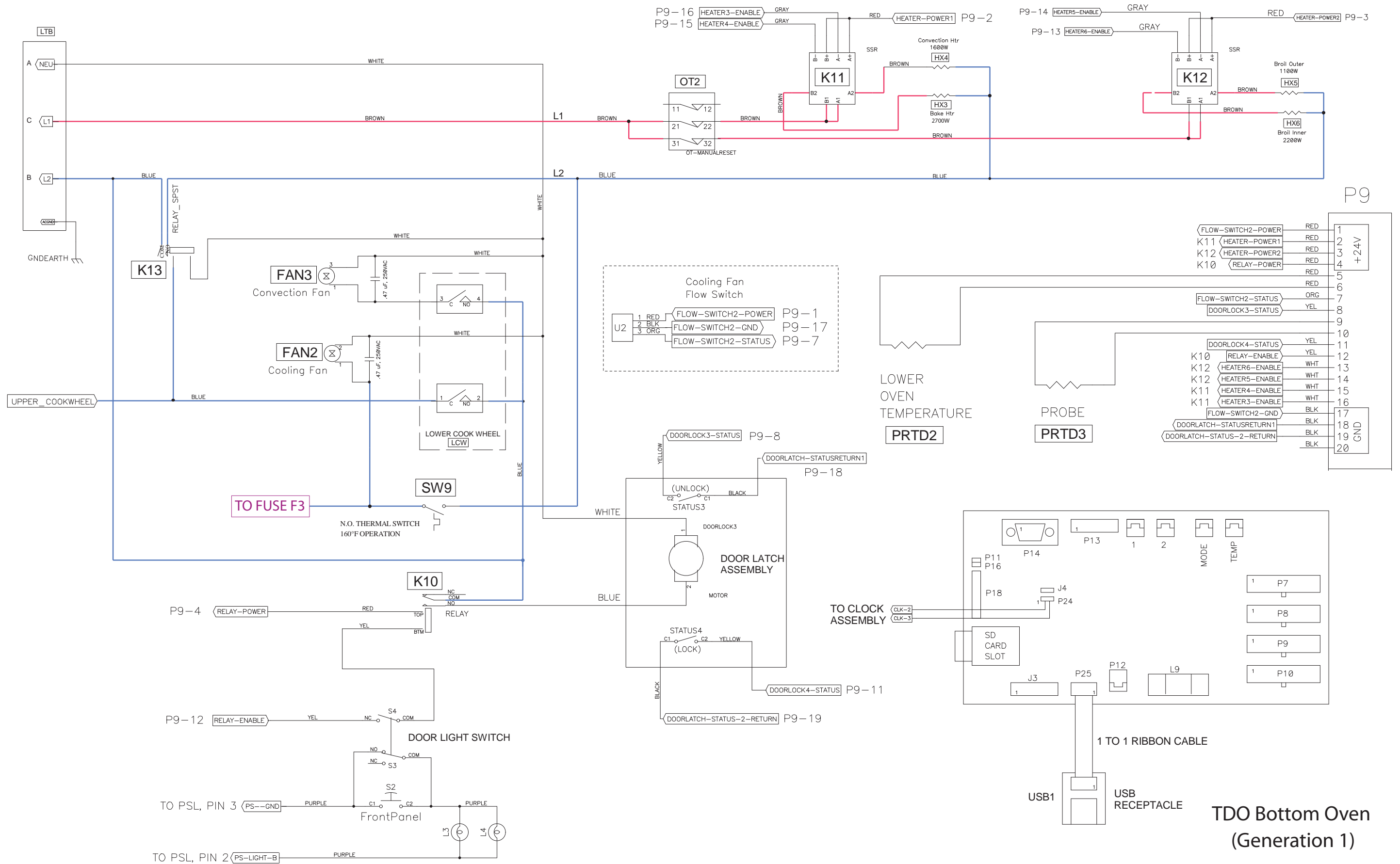

TDO Bottom Oven (Generation 1)

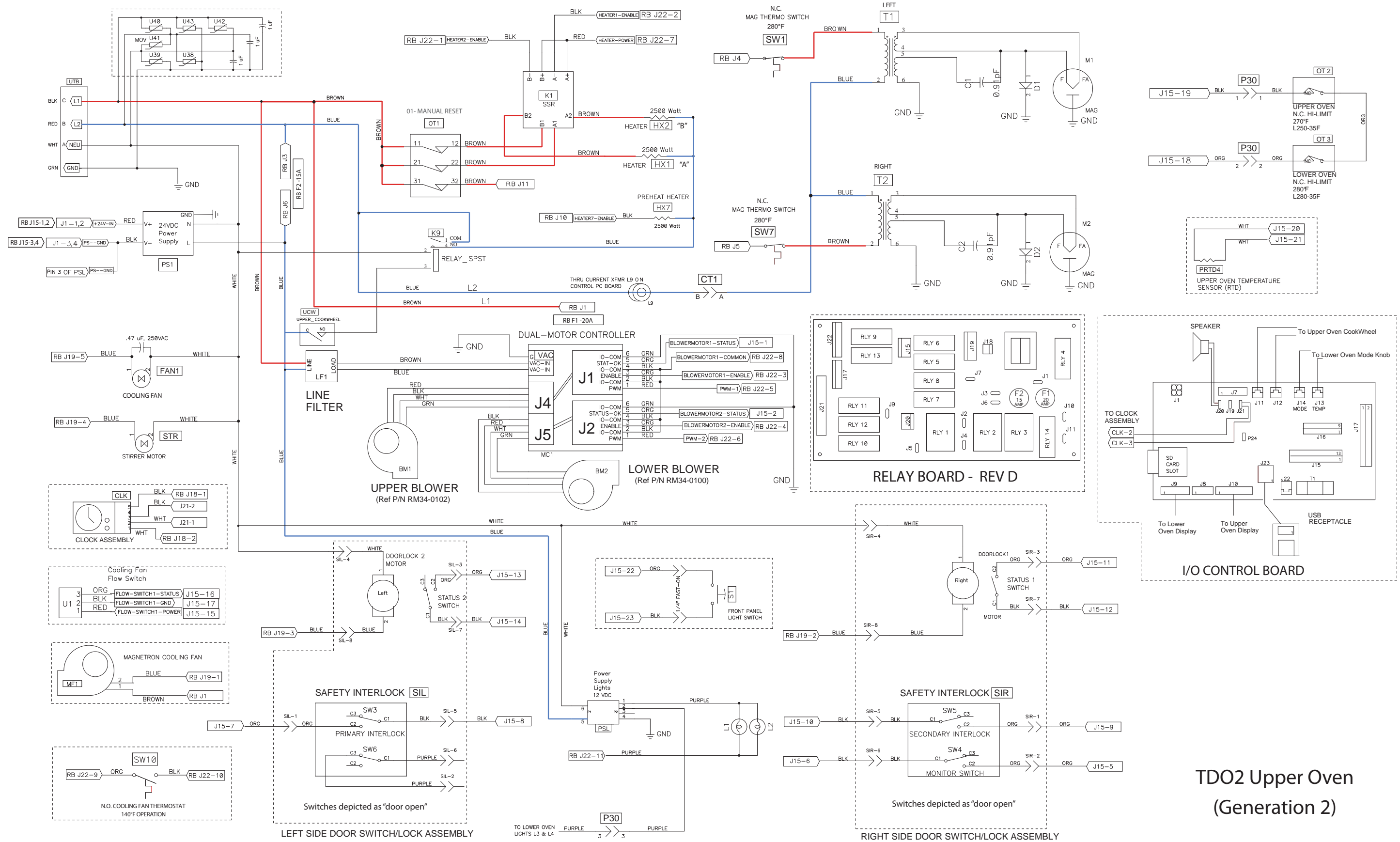

TDO2 Upper Oven (Generation 2)

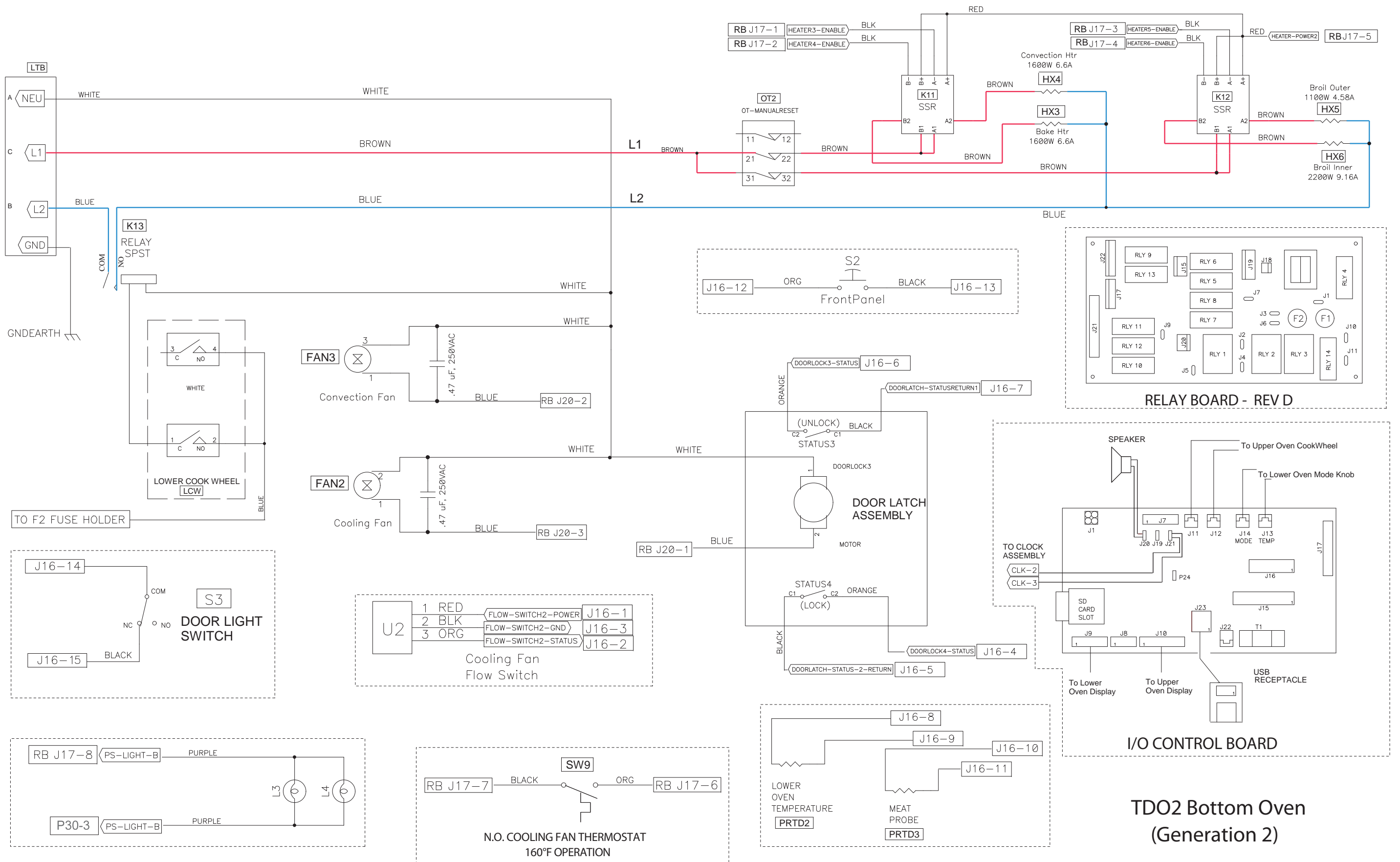

TDO2 Bottom Oven
(Generation 2)

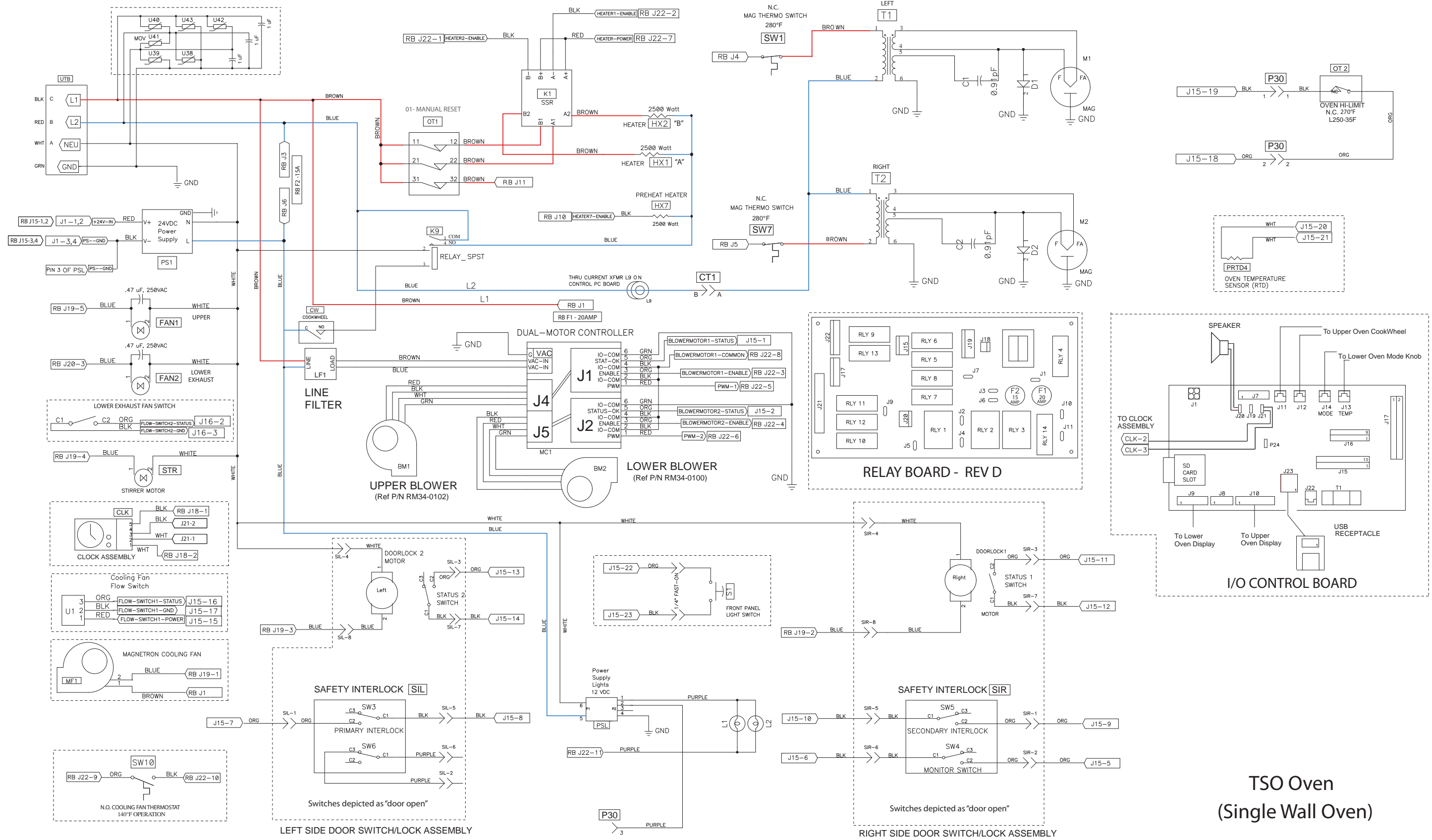

TSO Oven
(Single Wall Oven)

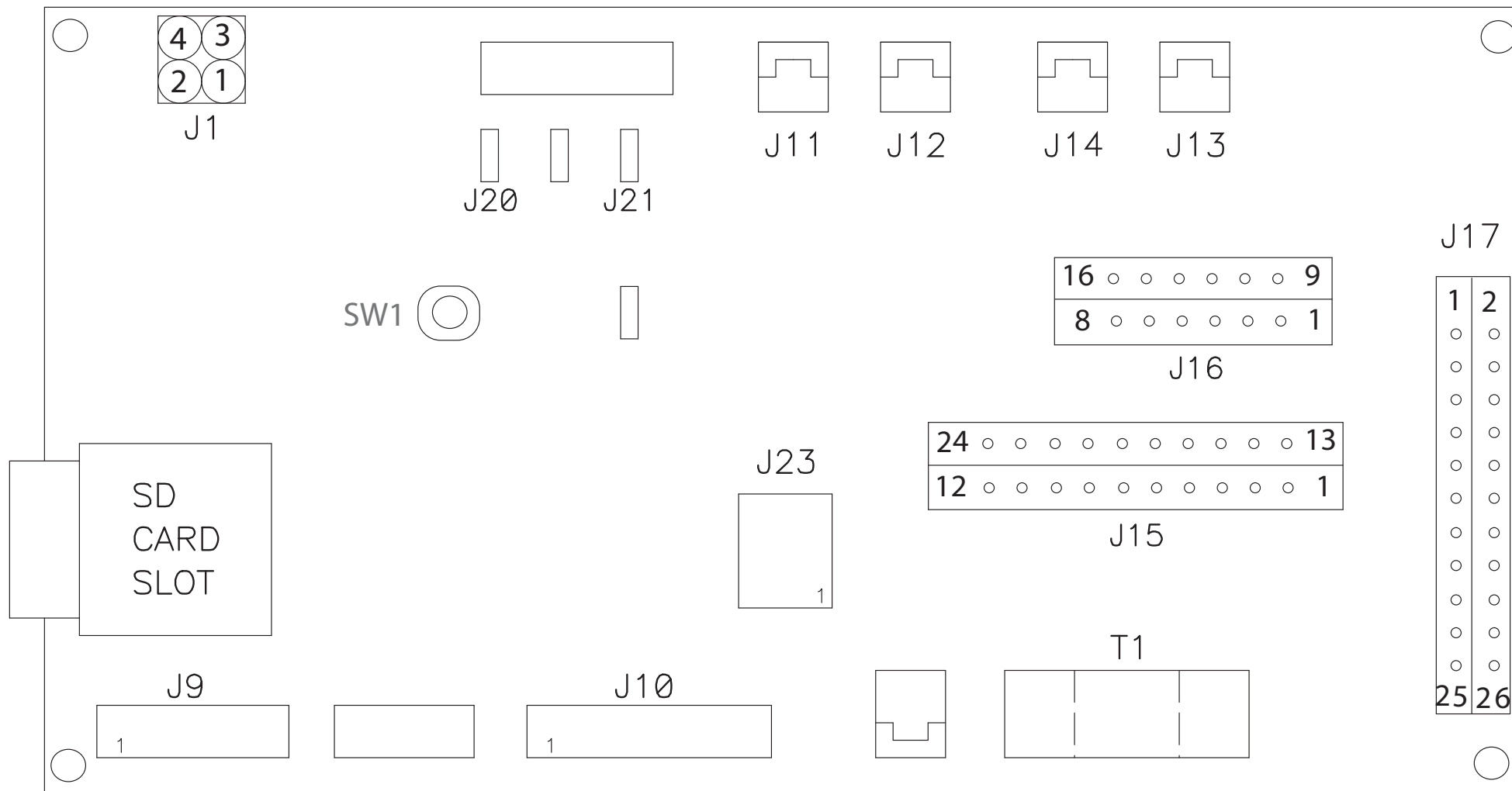

J1 - 1	+24VDC (input)
J1 - 2	+24VDC (input)
J1 - 3	Ground (input)
J1 - 4	Ground (input)

J9	Lower Oven Display
J10	Upper Oven Display
J11	Upper Oven Mode Control
J12	Upper Oven Mode Control
J14	Lower Oven Temp Control
J13	Lower Oven Mode Control
J20	Speaker
J21	Clock assembly
J23	USB connection
T 1	Current transformer
SW1	Master board reset

J17-1	HX1 Heater
J17-2	HX2 Heater
J17-3	Convection Heater
J17-4	Bake Heater
J17-5	Broil Outer Heater
J17-6	Broil Inner Heater
J17-7	Pre heat Heater
J17-8	Blower Upper
J17-9	Blower Lower
J17-10	PWM0
J17-11	PWM1
J17-12	Door Latch 1
J17-13	Door Latch 2
J17-14	Door Latch Lower
J17-15	Convection Fan
J17-16	Mag 1
J17-17	Mag 2
J17-18	Mag Fan
J17-19	Stirrer Motor
J17-20	Door Light
J17-21	Door Light Lower
J17-22	Cooling Fan
J17-23	Cooling Fan Lower
J17-24	Spare
J17-25	Spare
J17-26	Monitor Interlock

J15-1	Blower Status Upper
J15-2	Blower Status Lower
J15-3	Not used
J15-4	Not used
J15-5	Monitor (+)
J15-6	Monitor Return (-)
J15-7	Primary (+)
J15-8	Primary return (-)
J15-9	Secondary (+)
J15-10	Secondary return (-)
J15-11	Door lock R (+)
J15-12	Door lock R return (-)

J15-13	Door lock L (+)
J15-14	Door lock L return (-)
J15-15	Up cooling flow sw. +24VDC
J15-16	Up cooling flow sw. status
J15-17	Up cooling flow sw. return (-)
J15-18	Oven over temp (+)
J15-19	Oven over temp return (-)
J15-20	RTD Upper (+)
J15-21	RTD Upper (-)
J15-22	Up front panel light switch (+)
J15-23	Up front panel light switch (-)
J15-24	Not Used

J16-1	Low cooling flow sw. +24VDC
J16-2	Low cooling flow sw. status
J16-3	Low cooling flow sw. return (-)
J16-4	Low door lock status (+)
J16-5	Low door lock status return (-)
J16-6	Low door unlock status (+)
J16-7	Low door unlock return (-)
J16-8	RTD Lower (+)
J16-9	RTD Lower (-)
J16-10	RTD meat probe (+)
J16-11	RTD meat probe (-)
J16-12	Low front panel light switch (+)
J16-13	Low front panel light switch (-)
J16-14	Low door light switch (+)
J16-15	Low door light switch (-)
J16-16	Not Used

RWD/RWS GEN 2 CONTROL BOARD

Pin-out descriptions REV. A 9_08

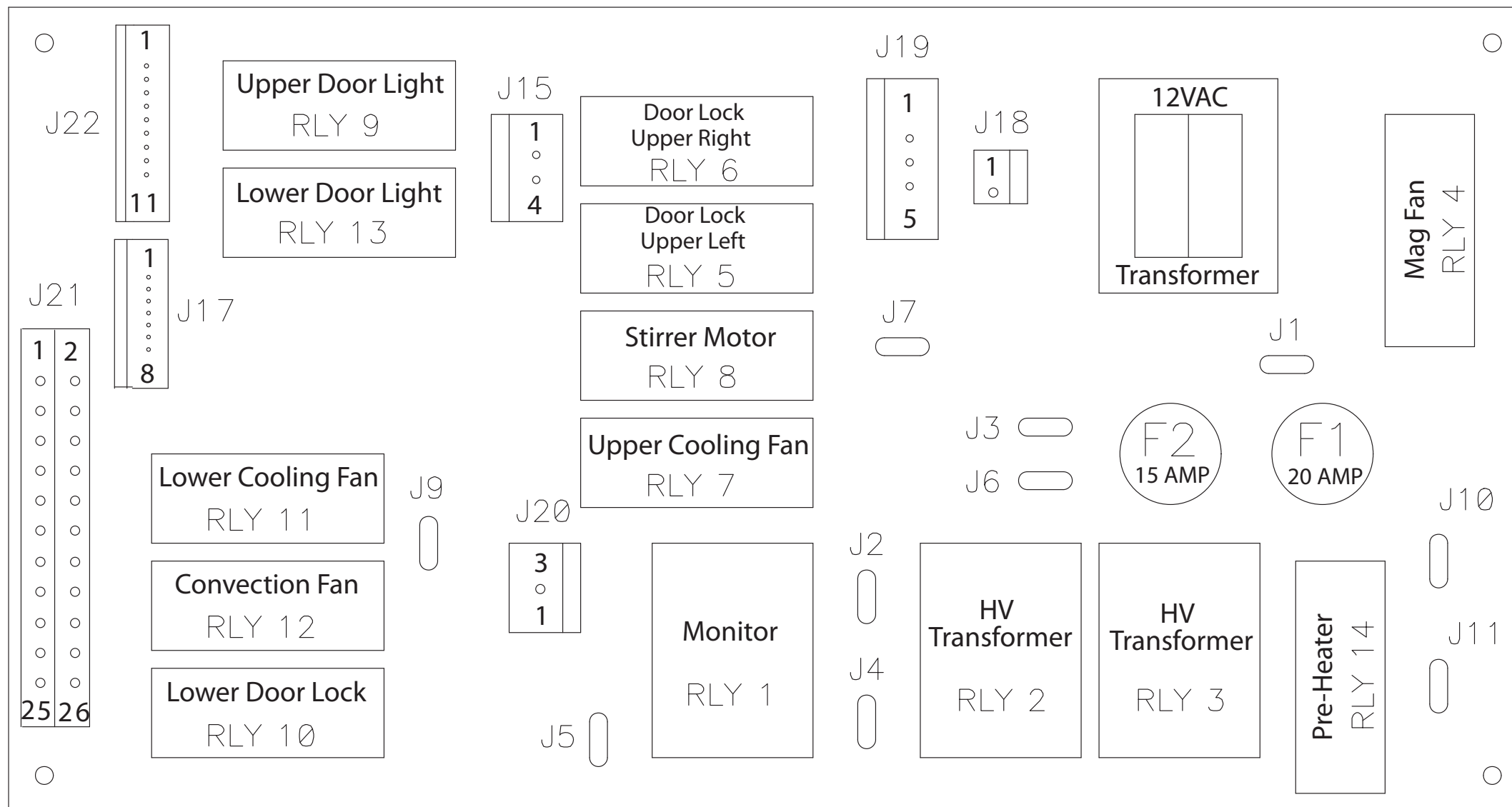

J20-3	Lower Cooling Fan (HV output)
J20-2	Convection Fan (HV output)
J20-1	Lower Door Lock (HV output)

Enable Inputs from I/O board	
J21-1	HX1 Heater
J21-2	HX2 Heater
J21-3	Convection Heater
J21-4	Bake Heater
J21-5	Broil Outer Heater
J21-6	Broil Inner Heater
J21-7	Pre heat Heater
J21-8	Blower Upper
J21-9	Blower Lower
J21-10	PWM0
J21-11	PWM1
J21-12	Door Latch 1
J21-13	Door Latch 2
J21-14	Door Latch Lower
J21-15	Convection Fan
J21-16	Mag 1
J21-17	Mag 2
J21-18	Mag Fan
J21-19	Stirrer Motor
J21-20	Door Light
J21-21	Door Light Lower
J21-22	Cooling Fan
J21-23	Cooling Fan Lower
J21-24	Spare
J21-25	Spare
J21-26	Monitor Interlock

J1	L1 Power (input to Mags RLY 2+3 thru F1)
J2	L2 Power (input to Monitor RLY 1)
J3	L2A Power (input to F2 fuse)
J4	T1-1 Power (L1 output to HV transformer)
J5	T2-2 Power (L1 output to HV transformer)
J6	L2-B Power (output from F2 fuse)
J7	L2 Power (input for Mag fan, Door locks 1+2, Upper cooling fan, Stirrer motor)
J9	L2 Power (input for Lower door lock, Lower cooling fan, and Convection motor)
J10	L1 Power input (from High Limit for Preheat)
J11	L1 Power output to Preheat Heater

J15-1	+24V (from PS)
J15-2	+24V (from PS)
J15-3	Ground (from PS)
J15-4	Ground (from PS)

J17-1	Convection Heater (output)
J17-2	Bake Heater (output)
J17-3	Broil Outer Heater (output)
J17-4	Broil Inner Heater (output)
J17-5	+24V (output)
J17-6	Cooling Fan CTL (input from thermostats)

J18-1	12.6VAC (output to clock)
J18-2	Common (output to clock)

J19-1	Mag Fan (HV output)
J19-2	Door Lock Up R (HV output)
J19-3	Door Lock Up L (HV output)
J19-4	Stirrer Motor (HV output)
J19-5	Cooling Fan Up (HV output)

J22-1	HX1 Heater output
J22-2	HX2 Heater output
J22-3	Upper Blower enable
J22-4	Lower Blower enable
J22-5	PWM0 0-10VDC upper
J22-6	PWM1 0-10VDC lower
J22-7	+24V (output)
J22-8	Ground
J22-9	Cooling Fan CTL
J22-10	Ground
J22-11	Door Light output

RWD/RWS GEN 2 RELAY BOARD
Pin-out descriptions REV. B 9_08

*This page intentionally
left blank.*

Appendix - Replacing Oven Components

Comprehensive Table of Oven Components

⚠ DANGER: Before removing or replacing any oven component, ensure the oven is removed from any power source (i.e., the breaker is turned off). Failure to do so can result in serious injury or death.

⚠ WARNING: Before removing or replacing any oven component, thoroughly read the safety instructions found at the front of this manual and in Oven Systems (Section 5) and Troubleshooting (Section 6). Adhere to all precautions and warnings outlined in these sections, as failure to do so could result in serious injury or death.

⚠ CAUTION: Before removing/installing any component, make sure it is disconnected from the wire harness (where applicable).

Part Details...		Locate the Part Here...		
Item	Part #	Oven	Page #	Illustration #
Access Panel, EC, Lower	RWD-9127	DWO Gen 1 & 2	A.22	A.17
Air Switch	102009	SWO	A.8	A.2
Blade, Convection Fan	104169	DWO Gen 1 & 2	A.28	A.25
Blower Motor Controller	100446	All	A.24	A.23
Blower Motor, Lower	RWD-9042	All	A.24	A.23
Blower Motor, Upper	RWD-9040	All	A.24	A.23
Blower, Dual	104164	All	A.14, A.16	A.7, A.9
Blower, Exhaust	104190	SWO	A.8	A.2
Bracket, Capacitor	104198	DWO Gen 1	A.14	A.7
Bracket, Control Assembly	RWD-9367	All	A.12	A.5
Bracket, Convection Fan	RWD-9238	DWO Gen 1 & 2	A.28	A.25
Bracket, Display, Lower	RWD-9142	DWO Gen 1 & 2	A.11	A.4
Bracket, Fuse and Terminal Block	RWD-9391	DWO Gen 1	A.14	A.8
Bracket, Relay Attachment, Gen 1	RWD-9126	DWO Gen 1	A.22	A.17
Bracket, Relay Attachment, Gen 2	RWD-9126	DWO Gen 2	A.22	A.18
Cable, Display, L.V., DWO	RWD-9427	DWO Gen 1 & 2	A.6	None
Cable, Display, Upper	RWD-9438	All	A.14, A.16	None
Cable, Interconnect, Relay Board	RWD-9542	DWO Gen 2 & SWO	A.16	None
Cable, Ribbon, 6"	104208	DWO Gen 1	A.6	None
Capacitor, H.V.	100213	All	A.14, A.20	A.7, A.13, A.14
Catalytic Converter	RWD-9066	All	A.24	A.23
Clock Assembly	RWD-9253	All	A.12	A.5
Clock Ring Gasket	RWD-9450	All	A.12	A.5
Clock Transformer	104139	DWO Gen 1	A.18	A.10
Control Board, Gen 1	RWD-3003	DWO Gen 1	A.18	A.10
Control Board, Gen 2	RWD-3015	DWO Gen 2 & SWO	A.18	A.11
Control Housing Assembly	N/A	All	A.11	A.3, A.4
Control Housing, Upper	RWD-9046	All	A.12	A.5
Controls Assembly	N/A	DWO Gen 1	A.14	A.7
Controls Assembly, Gen 2	N/A	DWO Gen 2 & SWO	A.16	A.9
Convection Fan	104158	DWO Gen 1 & 2	A.28	A.25
Convection Fan Assembly	N/A	DWO Gen 1 & 2	A.28	A.24

A.2 APPENDIX - REPLACING OVEN COMPONENTS

Part Details...		Locate the Part Here...		
Item	Part #	Oven	Page #	Illustration #
CookWheel Knob, Inner	RWD-9378	All	A.12	A.5
CookWheel Knob, Outer	RWD-9377	All	A.12	A.5
CookWheel Support Plate	RWD-9455	All	A.11, A.12	A.4, A.5
CookWheel Switch Assembly	RWD-9256	All	A.12	A.5
Cooling Fan, EC, Lower	104125	DWO Gen 1 & 2	A.22	A.17
Cooling Fan, EC, Upper	104114	All	A.14, A.16	A.7, A.9
Cord, Power	RWD-9412	All	A.14, A.16	None
Cover, Back, DWO	RWD-9184	DWO Gen 1 & 2	A.6	A.1
Cover, Back, SWO	RWS-9018	SWO	A.8	A.2
Cover, Bake Element	RWD-9242	DWO Gen 1 & 2	A.28	A.24
Cover, Blower Motors	RWD-9280	All	A.24	A.23
Cover, Door Switch	RWD-9359	All	A.24	A.22
Cover, Hinge Pocket	RWD-9472	All	A.24	A.21
Cover, Hinge Pocket, Lower	RWD-9149	DWO Gen 1 & 2	A.28	A.24
Cover, Meat Probe	RWD-9128	DWO Gen 1 & 2	A.28	A.24
Cover, Motor End	RWD-9282	All	A.24	A.23
Cover, Rear, Lower Oven	RWD-9225	DWO Gen 1 & 2	A.28	A.24
Cover, Waveguide	RWD-9164	All	A.24	A.21
Deflector, Broiler	RWD-9235	DWO Gen 1 & 2	A.28	A.24
Dial, Oven Mode	RWD-9379	DWO Gen 1 & 2	A.11	A.4
Dial, Temperature	RWD-9380	DWO Gen 1 & 2	A.11	A.4
Diode, H.V.	100481	All	A.14, A.20	A.7, A.13, A.14
Display Assembly, Upper, TFT	RWD-9294	All	A.12	A.5
Display, Lower	RWD-9295	DWO Gen 1 & 2	A.11	A.4
Diverter	RWD-9283	All	A.24	A.22
Diverter, Vent Outlet	RWD-9584	DWO Gen 2 & SWO	A.6, A.11	A.1, A.3
Door Receiver	104123	All	A.24, A.28	A.22, A.24
Door Sensing Switch	104229	DWO Gen 1 & 2	A.6	A.1
Door Skin, Replacement	RWD-3004-X	All	A.6, A.8	A.1, A.2
Door Switch, LHS	RWD-9187	All	A.24	A.21
Door Switch, RHS	RWD-9186	All	A.24	A.21
Door, Lower	RWD-3021	DWO Gen 1 & 2	A.6	A.1
Door, Speedcook Oven	RWD-3019-X	All	A.6, A.8	A.1, A.2
Door, Speedcook Oven, Inner	RWD-3022	All	A.6, A.8	A.1, A.2
Duct, Mag Cooling, LHS	RWD-9374	All	A.14, A.16	A.7, A.9
Duct, Mag Cooling, RHS	RWD-9373	All	A.14, A.16	A.7, A.9
Electrical Compartment, Lower, Gen 1	N/A	DWO Gen 1	A.6	A.1
Electrical Compartment, Lower, Gen 2	N/A	DWO Gen 2	A.6	A.1
Electrical Compartment, SWO	N/A	SWO	A.8	A.2
Electrical Compartment, Upper, Gen 1	N/A	DWO Gen 1	A.6	A.1
Electrical Compartment, Upper, Gen 2	N/A	DWO Gen 1	A.6	A.1
Element, Bake, Concealed (208V)	RWD-9464	DWO Gen 1 & 2	A.28	A.24
Element, Bake, Concealed (240V)	RWD-9354	DWO Gen 1 & 2	A.28	A.24
Element, Broil (208V)	RWD-9462	DWO Gen 1 & 2	A.28	A.24

Part Details...		Locate the Part Here...		
Item	Part #	Oven	Page #	Illustration #
Element, Broil (240V)	RWD-9351	DWO Gen 1 & 2	A.28	A.24
Element, Convection (208V)	RWD-9463	DWO Gen 1 & 2	A.28	A.24
Element, Convection (240V)	RWD-9353	DWO Gen 1 & 2	A.28	A.24
EMI Filter	104211	All	A.14, A.16	A.7, A.9
Front Trim, DWO	N/A	DWO Gen 1 & 2	A.6	A.1
Front Trim, SWO	N/A	SWO	A.8	A.2
Fuse Block	104183	DWO Gen 1	A.14	A.8
Fuse Holder	100579	DWO Gen 1	A.14	A.7
Fuse, 5 Amp	100635	DWO Gen 1	A.14	A.7
Fuse, 15 Amp, Gen 1	100601	DWO Gen 1	A.14	A.8
Fuse, 15 Amp, Gen 2	100602	DWO Gen 2 & SWO	A.18	A.11
Fuse, 20 Amp, Gen 1	100599	DWO Gen 1	A.14	A.8
Fuse, 20 Amp, Gen 2	100603	DWO Gen 2 & SWO	A.18	A.11
Handle, Lower Oven	RWD-9224	DWO Gen 1 & 2	A.6	A.1
Handle, Speedcook Oven	RWD-9011	All	A.6, A.8	A.1, A.2
Harness, Clock, Gen 2	RWD-9543	DWO Gen 2 & SWO	A.16	None
Harness, Failsafe, Microwave	RWD-9555	DWO Gen 1	A.6	None
Harness, Fuse, Cooling Fan	RWD-9553	DWO Gen 1	A.6	None
Harness, H.V., Lower Oven, Gen 2	RWD-9539	DWO Gen 2	A.22	None
Harness, L.V., Clock	RWD-9437	DWO Gen 1	A.14	None
Harness, L.V., Lower Oven, Gen 2	RWD-9541	DWO Gen 2	A.22	None
Harness, L.V., Upper Oven, Gen 2	RWD-9540	DWO Gen 2 & SWO	A.16	None
Harness, Lower Oven	RWD-9408	DWO Gen 1	A.22	None
Harness, Power, Lower, DWO	RWD-9429	DWO Gen 1 & 2	A.22	None
Harness, Power, Motor Controller	RWD-9559	DWO Gen 2 & SWO	A.16	None
Harness, Single	RWS-9002	SWO	A.8	None
Harness, Upper Oven	RWD-9407	DWO Gen 1	A.14	None
Harness, Wire, Gen 2	RWD-9538	DWO Gen 2 & SWO	A.16	None
Heater Cover Plate	RWD-9156	All	A.14, A.16	A.8, A.9
Heater, Upper Oven (208V)	RWD-9394	All	A.24	A.23
Heater, Upper Oven (240V)	RWD-9065	All	A.24	A.23
High Limit Switch	102075	All	A.14, A.16, A.22	A.8, A.9, A.17
Hinge Pocket, Lower, LHS	RWD-9119	DWO Gen 1 & 2	A.28	A.24
Hinge Pocket, Lower, RHS	RWD-9118	DWO Gen 1 & 2	A.28	A.24
Hinge Pocket, LHS	RWD-9098	All	A.24	A.22
Hinge Pocket, RHS	RWD-9097	All	A.24	A.22
Jetplate, Lower	RWD-9576	All	A.24	A.22
Jetplate, Upper	RWD-3017	All	A.24	A.22
Lamp, Halogen, Lower Oven	RWD-3016	DWO Gen 1 & 2	A.28	A.24
Lamp, Halogen, Upper Oven	RWD-3014	All	A.24	A.22
Latch Mechanism	RWD-9366	All	A.22	A.17
Light Switch	104141	All	A.11, A.12	A.4, A.5
M.O.V. Filter	RWD-9490	All	A.14, A.21	A.8, A.16
Mag Air Diverter Assembly, Gen 1	N/A	DWO Gen 1	A.14	A.8

A.4 APPENDIX - REPLACING OVEN COMPONENTS

Part Details...		Locate the Part Here...		
Item	Part #	Oven	Page #	Illustration #
Mag Air Diverter Assembly, Gen 2	N/A	DWO Gen 2 & SWO	A.16	A.9
Magnetron	104154	All	A.14, A.16	A.8, A.9
Microwave Stirrer Assembly	RWD-9275	All	A.24	A.21
Outer Frame, DWO	RWD-3006	DWO Gen 1 & 2	A.11	A.4
Outer Frame, SWO	RWS-9005	SWO	A.11	A.3
Oven, Lower	N/A	DWO Gen 1 & 2	A.6	A.1
Oven, Speedcook, DWO, Gen 1	N/A	DWO Gen 1 & 2	A.6	A.1
Oven, Speedcook, DWO, Gen 2	N/A	DWO Gen 1 & 2	A.6	A.1
Oven, Speedcook, SWO	N/A	SWO	A.8	A.2
Panel, Convection, Porcelain	RWD-9575	DWO Gen 1 & 2	A.28	A.24
Plate, Convection Fan	RWD-9237	DWO Gen 1 & 2	A.28	A.25
Power Supply (12VDC)	104128	All	A.18	A.12
Power Supply (24VDC)	104166	All	A.18	A.12
Power Supply Assembly	N/A	All	A.18	A.10, A.11
Power Supply Mounting Plate	RWD-9262	All	A.18	A.12
Rack	RWD-9167	All	A.24	A.22
Rack Guide	RWD-9385	DWO Gen 1 & 2	A.28	A.24
Rack, Lower Oven	RWD-9384	DWO Gen 1 & 2	A.28	A.24
Rack, Roller, Lower Oven	RWD-9383	DWO Gen 1 & 2	A.28	A.24
Receptacle, Meat Probe	104159	DWO Gen 1 & 2	A.28	A.24
Relay Assembly	N/A	DWO Gen 1	A.14	A.7
Relay Board	RWD-9545-FRU	DWO Gen 2 & SWO	A.18	A.11
Relay, K1	101281	All	A.21	A.15, A.16
Relay, K2	101273	DWO Gen 1	A.21	A.15
Relay, K3	101273	DWO Gen 1	A.21	A.15
Relay, K4	101273	DWO Gen 1	A.21	A.15
Relay, K5	101273	DWO Gen 1	A.21	A.15
Relay, K6	101273	DWO Gen 1	A.21	A.15
Relay, K7	101273	DWO Gen 1	A.21	A.15
Relay, K8	101273	DWO Gen 1	A.21	A.15
Relay, K9	104179	All	A.20, A.21	A.13, A.16
Relay, K10	104202	DWO Gen 1	A.22	A.19
Relay, K11	101281	DWO Gen 1 & 2	A.22	A.19, A.20
Relay, K12	101281	DWO Gen 1 & 2	A.22	A.19, A.20
Relay, K13	104179	DWO Gen 1 & 2	A.22	A.19, A.20
Relay/Power Assembly	N/A	DWO Gen 2 & SWO	A.16	A.9
RTD	RWD-9364	All	A.24, A.28	A.21, A.24
SD Card, Gen 1	RWD-9500	DWO Gen 1	A.18	A.10
SD Card, Gen 2	RWD-9562	DWO Gen 2 & SWO	A.18	A.11
Separator, Convection Fan	RWD-9223	DWO Gen 1 & 2	A.28	A.24
Snubber, Electrical	RWD-9497	All	A.14, A.16, A.22, A.28	A.7, A.9, A.17, A.25
Speaker	104214	All	A.12, A.18	A.6, A.10
Stand-Off, Broil Element	RWD-9215	DWO Gen 1 & 2	A.28	A.24
Stand-Off, Rear, Lower	RWD-9130	DWO Gen 1 & 2	A.28	A.24

Part Details...		Locate the Part Here...		
Item	Part #	Oven	Page #	Illustration #
Stirrer Motor, Gear	104174	All	A.14, A.16	A.7, A.9
Stirrer Motor, Hub	104175	All	A.14, A.16	A.7, A.9
Stirrer Shaft	RWD-9070	All	A.24	A.21
Stirrer, Coupling Hub	104133	All	A.24	A.21
Stirrer, Coupling Spider Insert	104134	All	A.24	A.21
Stirrer, Shaft Support	RWD-9077	All	A.24	A.21
Stirrer, Stud Plate	RWD-9072	All	A.24	A.21
Support, Rack, LHS	RWD-9165	All	A.24	A.22
Support, Rack, RHS	RWD-9166	All	A.24	A.22
Switch Assembly, Mode	RWD-9257	DWO Gen 1 & 2	A.11	A.4
Switch Assembly, Temperature	RWD-9258	DWO Gen 1 & 2	A.11	A.4
Terminal Block	104145	All	A.14, A.21, A.22	A.8, A.16, A.17, A.18
Thermostat, 140F, Close on Rise	102087	All	A.20	A.13, A.14
Thermostat, 160F, Close on Rise	104236	DWO Gen 1 & 2	A.22	A.17
Thermostat, 270F, Open on Rise	104228	All	A.8, A.24	A.2, A.23
Thermostat, 280F, Open on Rise	104167	All	A.14, A.17, A.22	A.7, A.17, A.9
Top Cover, Front	RWD-9356	All	A.6, A.8	A.1, A.2
Top Cover, Rear	RWD-9355	All	A.6, A.8	A.1, A.2
Transformer, H.V.	104137	All	A.14, A.17	A.8, A.9
USB Port, Gen 1	RWD-9453	DWO Gen 1	A.6	A.1
USB Port, Gen 2	103193	DWO Gen 2 & SWO	A.6, A.8	A.1, A.2
Wire, Canada, Black	RWD-9531	DWO Gen 1	A.22	None
Wire, Canada, Orange	RWD-9530	DWO Gen 1	A.22	None
Wire, Canada, Short	RWD-9529	DWO Gen 1	A.22	None
Wire, H.V., Capacitor/Diode	RWD-9435	All	A.14, A.17	None
Wire, H.V., Capacitor Magnetron	RWD-9434	DWO Gen 1	A.14	None
Wire, H.V., Capacitor/Transformer	RWD-9433	All	A.14, A.17	None
Wire, H.V., Ground, Diode	RWD-9436	All	A.14, A.17	None
Wire, L.V., P7, P8, & P10, Conn., Upper Oven	RWD-9431	DWO Gen 1	A.14	None
Wire, L.V., P9 Conn., DWO	RWD-9430	DWO Gen 1	A.22	None
Wire, Light Jumper, Lower Switch	RWD-9489	DWO Gen 1 & 2	A.6	None
Wire, Switch, Lower	RWD-9428	DWO Gen 2	A.22	None
Wire, Switch, Lower, Gen 1	RWD-9596	DWO Gen 1	A.6	None
Wire, Switch, Upper, Gen 1	RWD-9597	DWO Gen 1	A.14	None
Wire, Upper Switch	RWD-9432	DWO Gen 2 & SWO	A.17	None

Component and Assembly Location, DWO Gen 1 and Gen 2

⚠ DANGER: Before removing or replacing any oven component, ensure the oven is removed from any power source (i.e., the breaker is turned off). Failure to do so can result in serious injury or death.

⚠ WARNING: Before removing or replacing any oven component, thoroughly read the safety instructions found at the front of this manual and in Oven Systems (Section 5) and Troubleshooting (Section 6). Adhere to all precautions and warnings outlined in these sections, as failure to do so could result in serious injury or death.

⚠ CAUTION: Before removing/installing any component, make sure it is disconnected from the wire harness (where applicable).

Removing the Oven

In order to remove the oven from the wall, the two mounting screws (P/N: 104184), located on the inside of the Speedcook oven's outer trim, must be removed (additionally, some older DWO oven models have 2 cabinet screws in the lower oven's outer trim). The oven may be safely pulled away from the wall approximately 11" (280 mm) to remove the front top cover, lower EC access panel, and the door switch covers. Any further removal requires the oven to be fully removed from the wall and placed upon a cart capable of supporting approximately 410 lbs (186 kg).

Item Description	Item Part #	Hardware Description	Hardware Part Number(s)
Cable, Display, L.V., DWO	RWD-9427	None	None
Cable, Ribbon, 6"	104208	None	None
Cover, Back, DWO	RWD-9184	Screw, SH MTL, #8 x 1/2 Serrated PHTRH	101688 (x19)
Diverter, Vent Outlet	RWD-9584	None	None
Door Sensing Switch	104229	Screw, SH MTL, #8 x 1/2 Serrated PHTRH	101688 (x3)
Door Skin, Replacement	RWD-3004-X	None	None
Door, Lower	RWD-3021	None	None
Door, Speedcook Oven	RWD-3019-X	Screw, SH MTL, #8 x 1/2 Serrated PHTRH Cover, Hinge Pocket Screw, #8-32 x 3/8, PPH, THD-Forming, PLT	101688 (x4) RWD-9472 (x2) 104227 (x2)
Door, Speedcook Oven, Inner	RWD-3022	None	None
Electrical Compartment, Lower, Gen 1 (see pages A.22-A.23)	N/A	None	None
Electrical Compartment, Lower, Gen 2 (see pages A.22-A.23)	N/A	None	None
Electrical Compartment, Upper, Gen 1 (see pages A.13-A.15)	N/A	None	None
Electrical Compartment, Upper, Gen 2 (see pages A.16-A.17)	N/A	None	None
Front Trim, DWO (see pages A.10-A.11)	N/A	Screw, #8 x 3/8 PH MOD TRUSS CRES Screw, SH MTL, #8 x 1/2 Serrated PHTRH Screw, #8 x 2.00 PH MOD TRUSS SS	101682 (x16) 101688 (x4) 104184 (x2)
Handle, Lower Oven	RWD-9224	Bolt, Handle, Lower Oven	RWD-9457 (x2)
Handle, Speedcook Oven	RWD-9011	Bolt, Handle, Speedcook Oven	RWD-9458 (x2)
Harness, Failsafe, Microwave	RWD-9555	None	None
Harness, Fuse, Cooling Fan	RWD-9553	None	None
Oven, Lower (see pages A.28-A.29)	N/A	None	None

Item Description	Item Part #	Hardware Description	Hardware Part Number(s)
Oven, Speedcook, DWO, Gen 1 (see pages -A.25)	N/A	None	None
Oven, Speedcook, DWO, Gen 2 (see pages -A.25)	N/A	None	None
Top Cover, Front	RWD-9356	Screw, SH MTL, #8 x 1/2 Serrated PHTRH	101688 (x7)
Top Cover, Rear	RWD-9355	Screw, SH MTL, #8 x 1/2 Serrated PHTRH	101688 (x11)
USB Port, Gen 1	RWD-9453	Screw, 6-32 x .38, PFH, 100DEG, SS	101430 (x2)
USB Port, Gen 2	103193	Screw, SH MTL, #8 x 1/2 Serrated PHTRH Bracket, USB, Strap	101688 (x2) RWS-9026
Wire, Light Jumper, Lower Switch	RWD-9489	None	None
Wire, Switch, Lower, Gen 1	RWD-9596	None	None

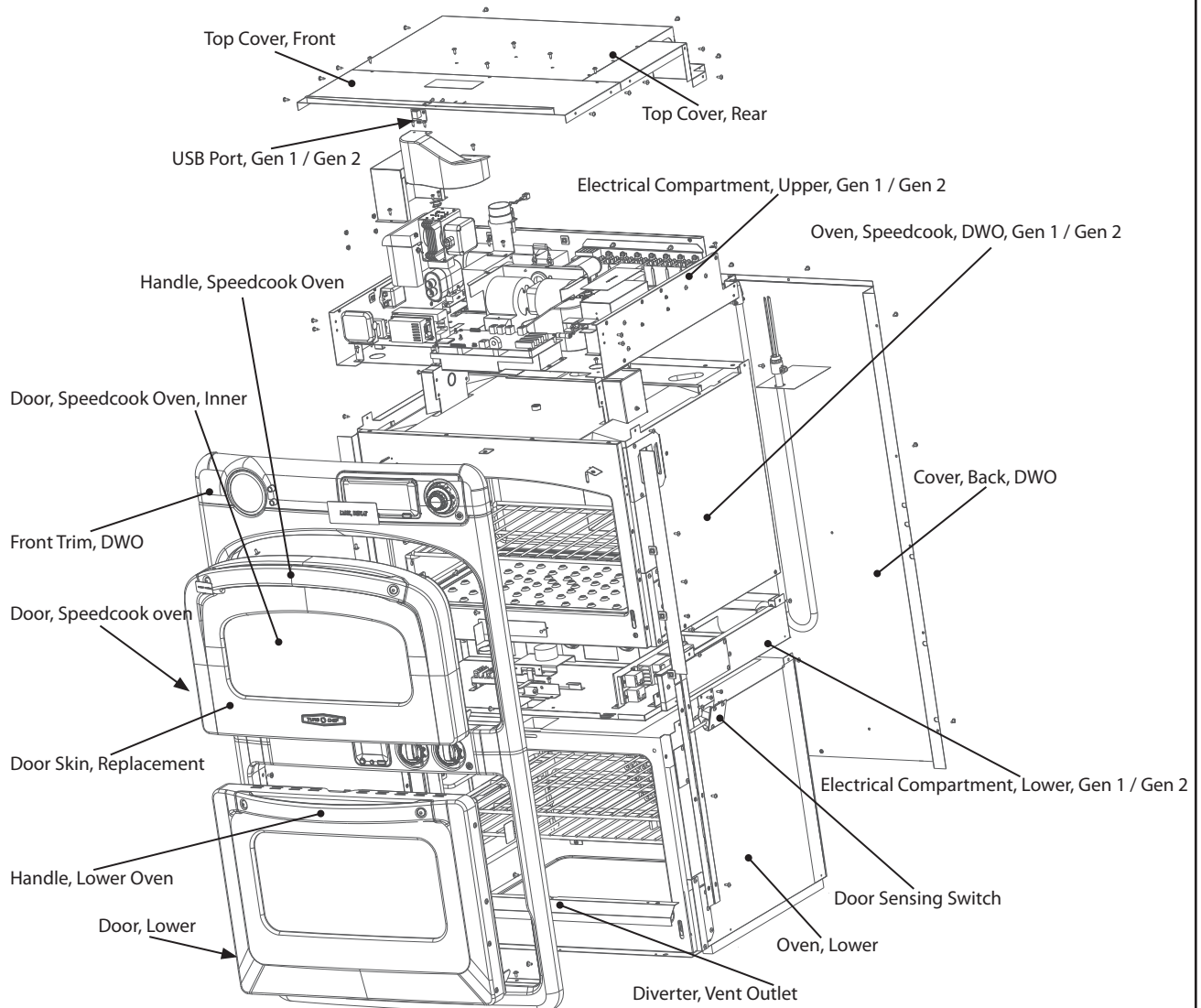

Figure A.1: Component and Assembly Location, DWO Gen 1 and Gen 2

Component and Assembly Location, SWO

⚠ DANGER: Before removing or replacing any oven component, ensure the oven is removed from any power source (i.e., the breaker is turned off). Failure to do so can result in serious injury or death.

⚠ WARNING: Before removing or replacing any oven component, thoroughly read the safety instructions found at the front of this manual and in Oven Systems (Section 5) and Troubleshooting (Section 6). Adhere to all precautions and warnings outlined in these sections, as failure to do so could result in serious injury or death.

⚠ CAUTION: Before removing/installing any component, make sure it is disconnected from the wire harness (where applicable).

Removing the Oven

In order to remove the oven from the wall, the two mounting screws (P/N: 104184), located on the inside of the Speedcook oven's outer trim, must be removed. The oven may be safely pulled away from the wall approximately 11" (280 mm) to remove the front top cover, lower EC access panel, and the door switch covers. Any further removal requires the oven to be fully removed from the wall and placed upon a cart capable of supporting approximately 230 lbs. (105 kg.).

Item Description	Item Part #	Hardware Description	Hardware Part Number(s)
Air Switch	102009	Screw, 4-40 x 5/8, PPH, SS	101550 (x2)
Blower, Exhaust	104190	Screw, SH MTL, #8 x 1/2 Serrated PHTRH	101688 (x2)
Cover, Back, SWO	RWS-9018	Screw, SH MTL, #8 x 1/2 Serrated PHTRH	101688 (x11)
Door Skin, Replacement	RWD-3004-X	None	None
Door, Speedcook Oven	RWD-3019-X	Screw, SH MTL, #8 x 1/2 Serrated PHTRH Cover, Hinge Pocket Screw, #8-32 x 3/8, PPH, THD-Forming, PLT	101688 (x4) RWD-9472 (x2) 104227 (x2)
Door, Speedcook Oven, Inner	RWD-3022	None	None
Electrical Compartment, SWO (see pages A.16-A.17)	N/A	None	None
Front Trim, SWO (see pages A.10-A.11)	N/A	Screw, #8 x 3/8 PH MOD TRUSS CRES Screw, SH MTL, #8 x 1/2 Serrated PHTRH Screw, #8 x 2.00 PH MOD TRUSS SS	101682 (x16) 101688 (x4) 104184 (x2)
Handle, Speedcook Oven	RWD-9011	Bolt, Handle, Speedcook Oven	RWD-9458 (x2)
Harness, Single	RWS-9002	None	None
Oven, Speedcook, SWO (see pages -A.25)	N/A	None	None
Thermostat, 270F, Open on Rise	104228	Screw, #6 x 1/2, PPHD, DRL-PT, SS	101687 (x2)
Top Cover, Front	RWD-9356	Screw, SH MTL, #8 x 1/2 Serrated PHTRH	101688 (x7)
Top Cover, Rear	RWD-9355	Screw, SH MTL, #8 x 1/2 Serrated PHTRH	101688 (x11)
USB Port, Gen 2	103193	Screw, SH MTL, #8 x 1/2 Serrated PHTRH Bracket, USB, Strap	101688 (x2) RWS-9026

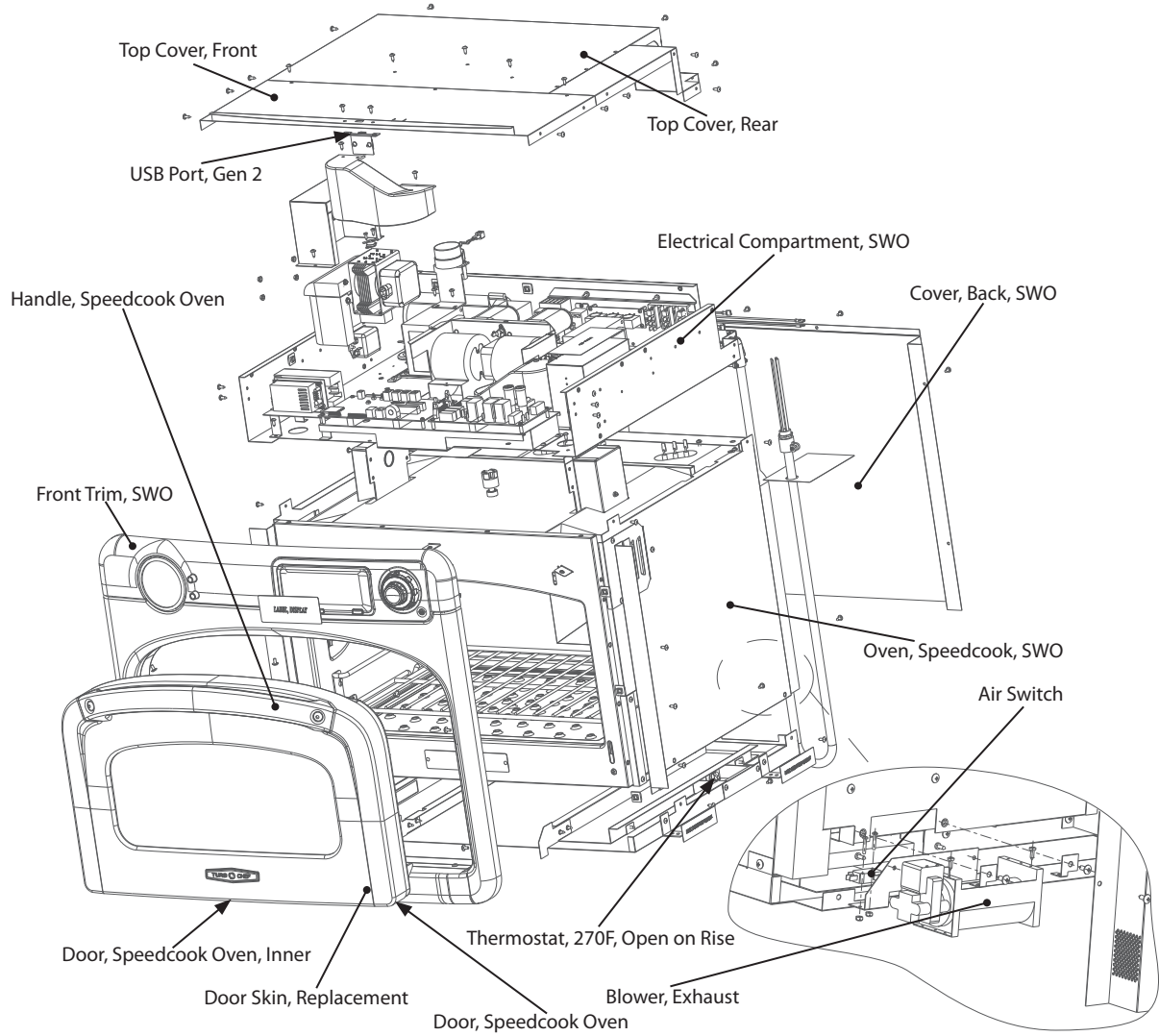





Figure A.2: Component and Assembly Location, SWO

Front Trim Assembly Detail

 **DANGER:** Before removing or replacing any oven component, ensure the oven is removed from any power source (i.e., the breaker is turned off). Failure to do so can result in serious injury or death.

 **WARNING:** Before removing or replacing any oven component, thoroughly read the safety instructions found at the front of this manual and in Oven Systems (Section 5) and Troubleshooting (Section 6). Adhere to all precautions and warnings outlined in these sections, as failure to do so could result in serious injury or death.

 **CAUTION:** Before removing/installing any component, make sure it is disconnected from the wire harness (where applicable).

Front Trim Assembly Removal

 **WARNING:** When removing the front trim assembly, ensure that the surrounding floor and cabinetry are protected from damage.

 **WARNING:** Failure to properly reconnect the wiring harness will result in damage to critical oven components. Carefully note the orientation and location of every wire connection.

1. Remove the oven door(s) (see pages 5.2-5.3 and 5.5-5.6).
2. Remove the 2 cabinet screws from the speedcook oven frame (additionally, some older DWO oven models have 2 cabinet screws in the lower oven frame).
3. Pull the oven from the wall approximately 11" (280 mm).
4. Remove the Front Top Cover and detach the USB port from the control board.
5. Detach the Control Housing Assembly from the Upper Electrical Compartment by removing the 2 screws from each of the Control Assembly Brackets.
6. Remove all screws securing the Front Trim Assembly to the oven's frame.
7. Disconnect the wiring harness from the electrical components in the Control Housing Assembly.
8. Remove the Diverter, Vent Outlet from the bottom of the oven.
9. Disconnect the wiring harness from the lower oven control components (if applicable).
10. Remove the front frame and place in a secured location.

Item Description	Item Part #	Hardware Description	Hardware Part Number(s)
Bracket, Display, Lower	RWD-9142	Screw, #8 x 1/2, PHPH, PLT	101689 (x2 each)
Control Housing Assembly (see pages A.12-A.13)	N/A	Screw, #8 x 3/4, PPHD, PLT-STL	104178 (x5)
CookWheel Support Plate	RWD-9455	None	None
Dial, Oven Mode	RWD-9379	None	None
Dial, Temperature	RWD-9380	None	None
Display, Lower	RWD-9295	None	None
Diverter, Vent Outlet	RWD-9584	Screw, #8 x 3/8 PH MOD TRUSS CRES Clip, Press-On Nut, #8, .5 x .5	101682 (x3) 104189
Light Switch	104141	Screw, #8 x 1/2, PHPH, PLT	101689 (x2)
Outer Frame, DWO	RWD-3006	None	None
Outer Frame, SWO	RWS-9005	None	None
Switch Assembly, Mode	RWD-9257	Screw, #8-32 x 3/8, PPHD, INT SEMS, SS	102921 (x2)
Switch Assembly, Temperature	RWD-9258	Screw, #8-32 x 3/8, PPHD, INT SEMS, SS	102921 (x2)

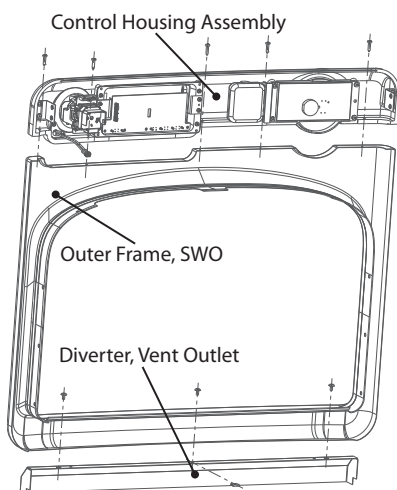

Figure A.3: Front Trim Assembly Details, SWO

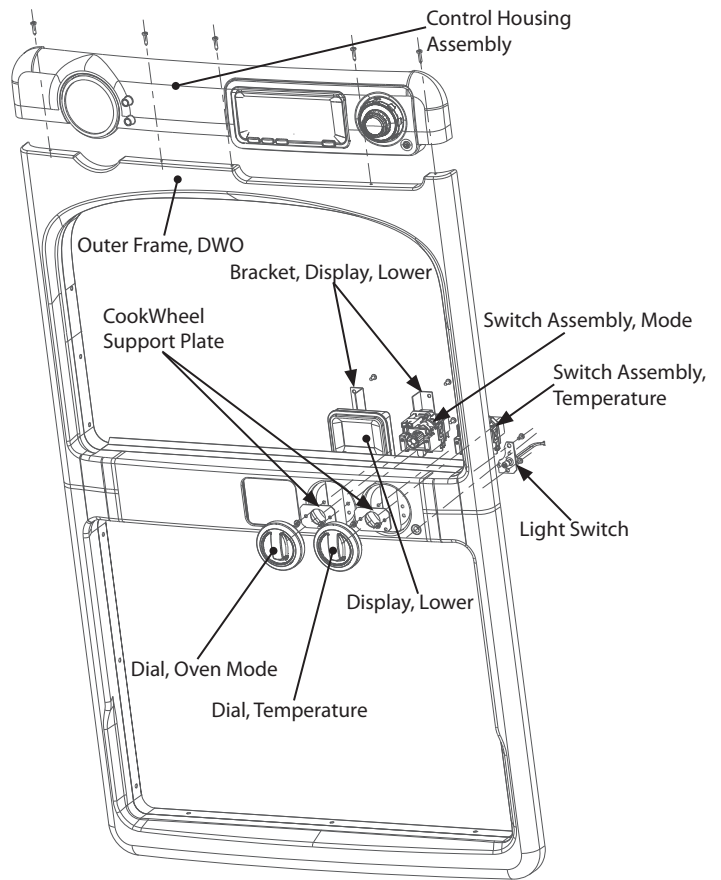

Figure A.4: Front Trim Assembly Details, DWO

Control Housing Detail

⚠ DANGER: Before removing or replacing any oven component, ensure the oven is removed from any power source (i.e., the breaker is turned off). Failure to do so can result in serious injury or death.

⚠ WARNING: Before removing or replacing any oven component, thoroughly read the safety instructions found at the front of this manual and in Oven Systems (Section 5) and Troubleshooting (Section 6). Adhere to all precautions and warnings outlined in these sections, as failure to do so could result in serious injury or death.

⚠ CAUTION: Before removing/installing any component, make sure it is disconnected from the wire harness (where applicable).

Item Description	Item Part #	Hardware Description	Hardware Part Number(s)
Bracket, Control Assembly	RWD-9367	Screw, #8-32 x 3/8, PPHD, INT SEMS, SS	102921 (x2 each)
Clock Assembly	RWD-9253	Screw, #8-32 x 3/8, PPHD, INT SEMS, SS	102921 (x4)
Clock Ring Gasket	RWD-9450	None	None
Control Housing, Upper	RWD-9046	None	None
CookWheel Knob, Inner	RWD-9378	None	None
CookWheel Knob, Outer	RWD-9377	None	None
CookWheel Support Plate	RWD-9455	None	None
CookWheel Switch Assembly	RWD-9256	Screw, #8-32 x 5/8 LG, SEMS, PPHD, SS	102926 (x2)
Display Assembly, Upper, TFT	RWD-9294	Screw, #6-32 x 3/8, INT TOOTH, PPH, SS	102911 (x4)
Light Switch	104141	Screw, #6-32 x 3/8, INT TOOTH, PPH, SS	102911 (x2)
Speaker	104214	Screw, SH MTL, #8 x 1/2 Serrated PHTRH Bracket, Speaker	101688 (x2) RWD-9567

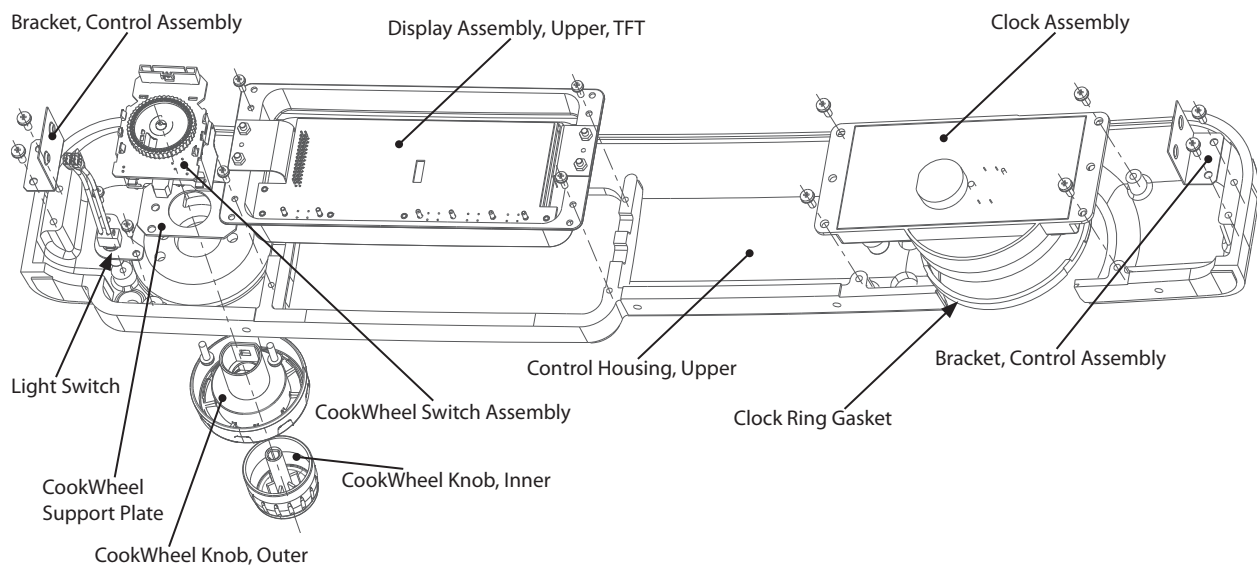

Figure A.5: Control Housing Detail, DWO Gen 1

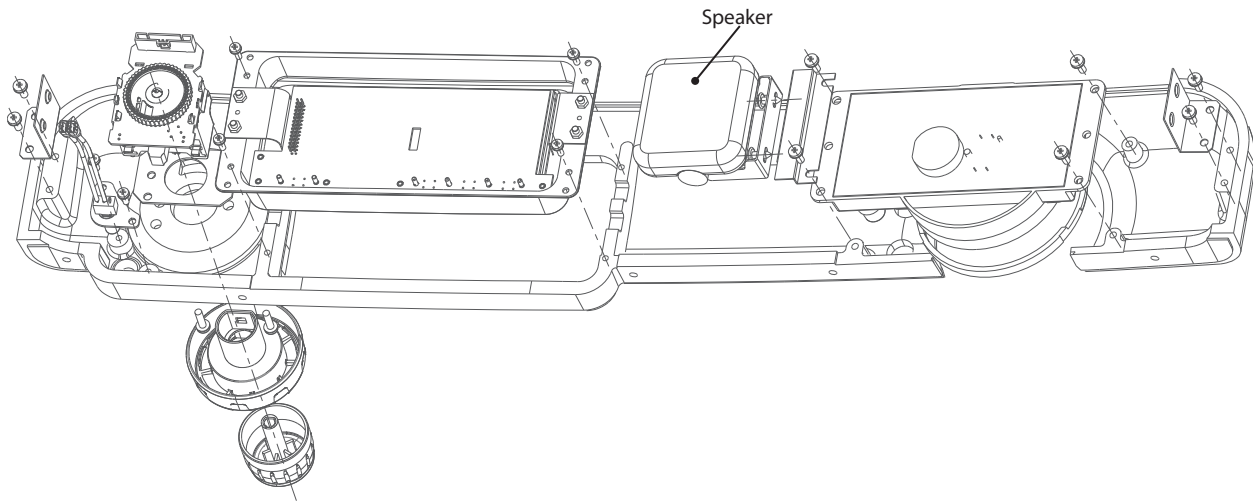

Figure A.6: Control Housing Detail, DWO Gen 2 and SWO (differences)

Upper Electrical Compartment, DWO Gen 1

⚠ DANGER: Before removing or replacing any oven component, ensure the oven is removed from any power source (i.e., the breaker is turned off). Failure to do so can result in serious injury or death.

⚠ WARNING: Before removing or replacing any oven component, thoroughly read the safety instructions found at the front of this manual and in Oven Systems (Section 5) and Troubleshooting (Section 6). Adhere to all precautions and warnings outlined in these sections, as failure to do so could result in serious injury or death.

⚠ CAUTION: Before removing/installing any component, make sure it is disconnected from the wire harness (where applicable).

Differentiating Between DWO Gen 1 and DWO Gen 2

Use the serial number to tell if the oven being serviced is a DWO Gen 1 or DWO Gen 2 oven. To view the serial number, open the Speedcook oven door and locate the serial plate (between the Speedcook oven door's hinges). If the serial number's first five characters are "TDO2D" (or "TSO2D" for SWO models), the oven is a Gen 2 oven. If the first five characters are NOT "TDO2D" (or "TSO2D"), the oven is a DWO Gen 1 oven.

If the oven being serviced is a DWO Gen 2 or SWO oven proceed to page A.16 for those model's upper electrical compartment illustrations.

A.14 APPENDIX - REPLACING OVEN COMPONENTS

Item Description	Item Part #	Hardware Description	Hardware Part Number(s)
Blower, Dual	104164	Screw, SH MTL, #8 x 1/2 Serrated PHTRH	101688 (x2)
Bracket, Capacitor	104198	Screw, SH MTL, #8 x 1/2 Serrated PHTRH	101688
Bracket, Fuse and Terminal Block	RWD-9391	Screw, SH MTL, #8 x 1/2 Serrated PHTRH	101688 (x2)
Cable, Display, Upper	RWD-9438	None	None
Capacitor, H.V.	100213	None	None
Controls Assembly (see pages A.18-A.19)	N/A	Screw, SH MTL, #8 x 1/2 Serrated PHTRH	101688 (x6)
Cooling Fan, EC, Upper	104114	Screw, SH MTL, #8 x 1/2 Serrated PHTRH	101688 (x3)
Cord, Power	RWD-9412	None	None
Diode, H.V.	100481	Screw, SH MTL, #8 x 1/2 Serrated PHTRH	101688 (x2)
Duct, Mag Cooling, LHS	RWD-9374	Screw, SH MTL, #8 x 1/2 Serrated PHTRH	101688 (x3)
Duct, Mag Cooling, RHS	RWD-9373	Screw, SH MTL, #8 x 1/2 Serrated PHTRH	101688 (x3)
EMI Filter	104211	Screw, SH MTL, #8 x 1/2 Serrated PHTRH	101688 (x2)
Fuse Block	104183	Screw, SH MTL, #8 x 1/2 Serrated PHTRH	101688 (x2)
Fuse Holder	100579	Screw, SH MTL, #8 x 1/2 Serrated PHTRH	101688 (x2)
Fuse, 5 Amp	100635	None	None
Fuse, 15 Amp, Gen 1	100601	None	None
Fuse, 20 Amp, Gen 1	100599	None	None
Harness, L.V., Clock	RWD-9437	None	None
Harness, Upper Oven	RWD-9407	None	None
Heater Cover Plate	RWD-9156	Screw, SH MTL, #8 x 1/2 Serrated PHTRH	101688 (x8)
High Limit Switch	102075	Screw, SH MTL, #8 x 1/2 Serrated PHTRH Bracket, Hi Limit Screw, M4X 0.7 x 8, PPHD, INT Tooth, SS	101688 (x2) RWD-9388 101672 (x2)
M.O.V. Filter	RWD-9490	Standoff, #6-32 x 5/8, F/F, PLTD Screw, #6-32 x 1/4 LG, PPH, SS	101951 (x3) 101565 (x3)
Mag Air Diverter Assembly, Gen 1 (see page A.20)	N/A	Screw, SH MTL, #8 x 1/2 Serrated PHTRH	101688 (x2)
Magnetron	104154	Nut, Hex Flanged, M5, Yellow Zinc	101001 (x4 each)
Relay Assembly (see page A.21)	N/A	Screw, #8-32 x 5/8 LG, SEMS, PPHD, SS	102926 (x2)
Snubber, Electrical	RWD-9497	None	None
Stirrer Motor, Gear	104174	Screw, M3 x 8mm LG, PPHD, S.S.	101668 (x2)
Stirrer Motor, Hub	104175	None	None
Terminal Block	104145	Screw, #8 x 3/4, PPHD, PLT-STL	104178 (x2)
Thermostat, 280F, Open on Rise	104167	Screw, #6 x 1/2, PPHD, DRL-PT, SS	101687 (x2)
Transformer, H.V.	104137	Screw, SH MTL, #8 x 1/2 Serrated PHTRH	101688 (x4)
Wire, H.V., Capacitor/Diode	RWD-9435	None	None
Wire, H.V., Capacitor Magnetron	RWD-9434	None	None
Wire, H.V., Capacitor/Trans- former	RWD-9433	None	None
Wire, H.V., Ground, Diode	RWD-9436	None	None
Wire, L.V., P7, P8, & P10, Conn., Upper Oven	RWD-9431	None	None
Wire, Switch, Upper, Gen 1	RWD-9597	None	None

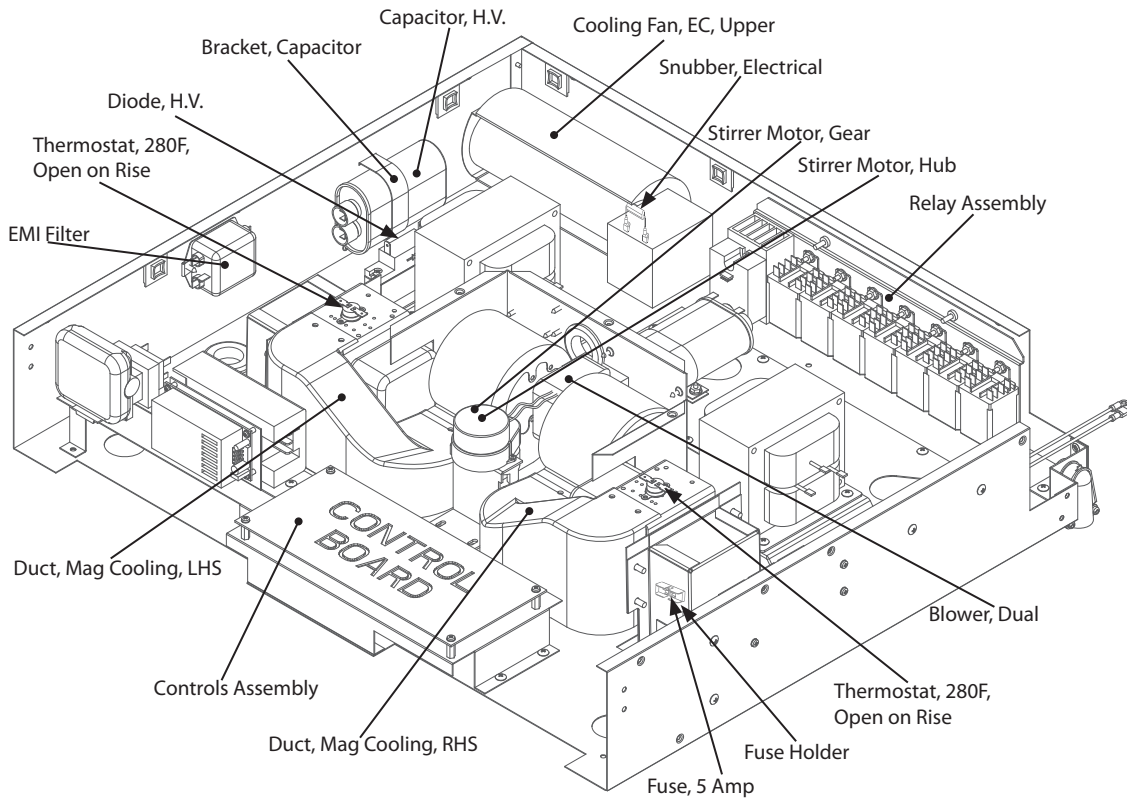

Figure A.7: Control Housing Detail, DWO Gen 1, Front View

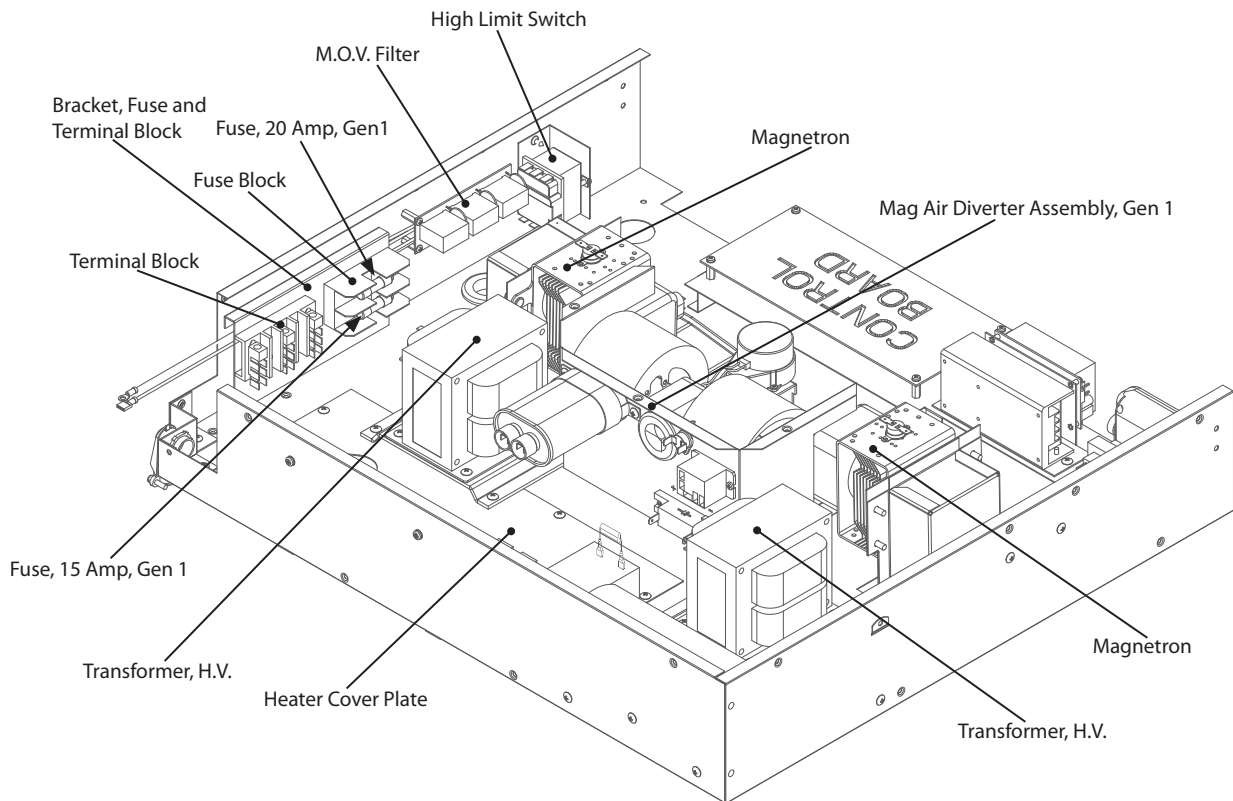

Figure A.8: Control Housing Detail, DWO Gen 1, Rear View

Upper Electrical Compartment, DWO Gen 2 and SWO

⚠ DANGER: Before removing or replacing any oven component, ensure the oven is removed from any power source (i.e., the breaker is turned off). Failure to do so can result in serious injury or death.

⚠ WARNING: Before removing or replacing any oven component, thoroughly read the safety instructions found at the front of this manual and in Oven Systems (Section 5) and Troubleshooting (Section 6). Adhere to all precautions and warnings outlined in these sections, as failure to do so could result in serious injury or death.

⚠ CAUTION: Before removing/installing any component, make sure it is disconnected from the wire harness (where applicable).

Differentiating Between DWO Gen 1 and DWO Gen 2

Use the serial number to tell if the oven being serviced is a DWO Gen 1 or DWO Gen 2 oven. To view the serial number, open the Speedcook oven door and locate the serial plate (between the Speedcook oven door's hinges). If the serial number's first five characters are "TDO2D" (or "TSO2D" for SWO models), the oven is a Gen 2 oven. If the first five characters are NOT "TDO2D" (or "TSO2D"), the oven is a DWO Gen 1 oven.

If the oven being serviced is a DWO Gen 1 oven proceed to page A.14 for that model's upper electrical compartment illustrations.

Item Description	Item Part #	Hardware Description	Hardware Part Number(s)
Blower, Dual	104164	Screw, SH MTL, #8 x 1/2 Serrated PHTRH	101688 (x2)
Cable, Display, Upper	RWD-9438	None	None
Cable, Interconnect, Relay Board	RWD-9542	None	None
Controls Assembly, Gen 2 (see pages A.18-A.19)	N/A	Screw, SH MTL, #8 x 1/2 Serrated PHTRH	101688 (x5)
Cooling Fan, EC, Upper	104114	Screw, SH MTL, #8 x 1/2 Serrated PHTRH	101688 (x3)
Cord, Power	RWD-9412	None	None
Duct, Mag Cooling, LHS	RWD-9374	Screw, SH MTL, #8 x 1/2 Serrated PHTRH	101688 (x3)
Duct, Mag Cooling, RHS	RWD-9373	Screw, SH MTL, #8 x 1/2 Serrated PHTRH	101688 (x3)
EMI Filter	104211	Screw, SH MTL, #8 x 1/2 Serrated PHTRH	101688 (x2)
Harness, Clock, Gen 2	RWD-9543	None	None
Harness, L.V., Upper Oven, Gen 2	RWD-9540	None	None
Harness, Power, Motor Controller	RWD-9559	None	None
Harness, Wire, Gen 2	RWD-9538	None	None
Heater Cover Plate	RWD-9156	Screw, SH MTL, #8 x 1/2 Serrated PHTRH	101688 (x8)
High Limit Switch	102075	Screw, SH MTL, #8 x 1/2 Serrated PHTRH Bracket, Hi Limit Screw, M4X 0.7 x 8, PPHD, INT Tooth, SS	101688 (x2) RWD-9388 101672 (x2)
Mag Air Diverter Assembly, Gen 2 (see page A.20)	N/A	Screw, SH MTL, #8 x 1/2 Serrated PHTRH	101688 (x2)
Magnetron	104154	Nut, Hex Flanged, M5, Yellow Zinc	101001 (x4)
Relay/Power Assembly (see page A.21)	N/A	Screw, #8-32 x 5/8 LG, SEMS, PPHD, SS	102926 (x2)
Snubber, Electrical	RWD-9497	None	None
Stirrer Motor, Gear	104174	Screw, M3 x 8mm LG, PPHD, S.S.	101668 (x2)
Stirrer Motor, Hub	104175	None	None

Item Description	Item Part #	Hardware Description	Hardware Part Number(s)
Thermostat, 280F, Open on Rise	104167	Screw, #6 x 1/2, PPHD, DRL-PT, SS	101687 (x2)
Transformer, H.V.	104137	Screw, SH MTL, #8 x 1/2 Serrated PHTRH	101688 (x4)
Wire, H.V., Capacitor/Diode	RWD-9435	None	None
Wire, H.V., Capacitor/Transformer	RWD-9433	None	None
Wire, H.V., Ground, Diode	RWD-9436	None	None
Wire, Upper Switch	RWD-9432	None	None

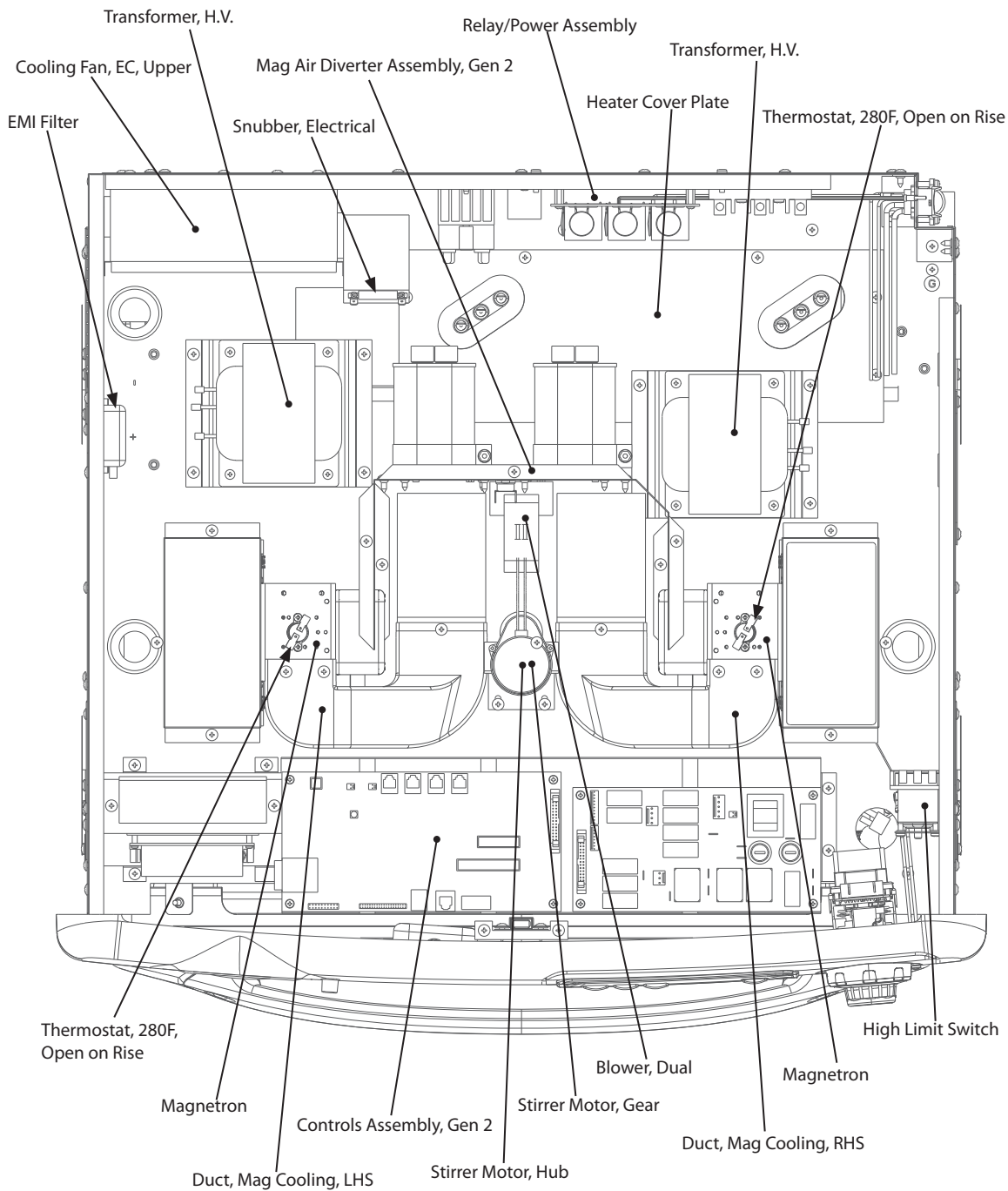

Figure A.9: Control Housing Detail, DWO Gen 2 and SWO

Controls Assembly Detail, DWO Gen 1, DWO Gen 2, and SWO

⚠ DANGER: Before removing or replacing any oven component, ensure the oven is removed from any power source (i.e., the breaker is turned off). Failure to do so can result in serious injury or death.

⚠ WARNING: Before removing or replacing any oven component, thoroughly read the safety instructions found at the front of this manual and in Oven Systems (Section 5) and Troubleshooting (Section 6). Adhere to all precautions and warnings outlined in these sections, as failure to do so could result in serious injury or death.

⚠ CAUTION: Before removing/installing any component, make sure it is disconnected from the wire harness (where applicable).

Item Description	Item Part #	Hardware Description	Hardware Part Number(s)
Clock Transformer	104139	Screw, SH MTL, #8 x 1/2 Serrated PHTRH	101688 (x2)
Control Board, Gen 1	RWD-3003	Screw, #6-32 x 3/8, INT TOOTH, PPH, SS	102911 (x4)
Control Board, Gen 2	RWD-3015	Screw, #6-32 x 3/8, INT TOOTH, PPH, SS	102911 (x4)
Fuse, 15 Amp, Gen 2	100602	None	None
Fuse, 20 Amp, Gen 2	100603	None	None
Power Supply (12VDC)	104128	Screw, PPH, SS, 4-40UNC x .25 LG	101520 (x4)
Power Supply (24VDC)	104166	Screw, #6-32 x 3/8, INT TOOTH, PPH, SS	102911 (x3)
Power Supply Assembly	N/A	Screw, SH MTL, #8 x 1/2 Serrated PHTRH	101688 (x2)
Power Supply Mounting Plate	RWD-9262	None	None
Relay Board	RWD-9545-FRU	Screw, #6-32 x 3/8, INT TOOTH, PPH, SS	102911 (x4)
SD Card, Gen 1	RWD-9500	None	None
SD Card, Gen 2	RWD-9562	None	None
Speaker	104214	Screw, SH MTL, #8 x 1/2 Serrated PHTRH	101688 (x2)

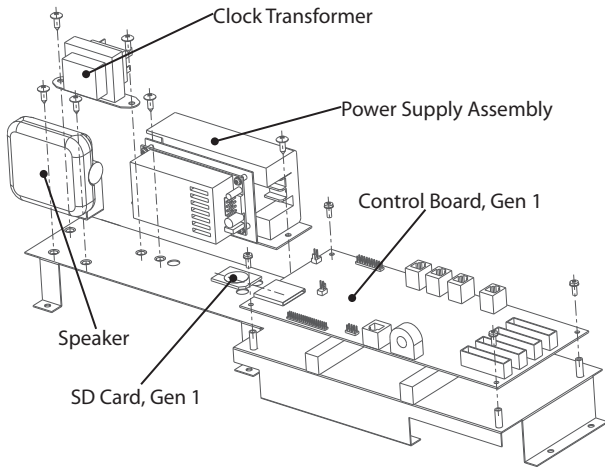

Figure A.10: Controls Assembly Detail, DWO Gen 1

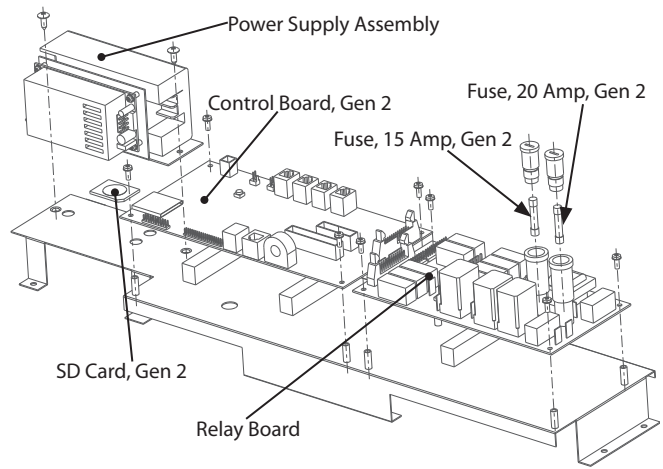

Figure A.11: Controls Assembly Detail, DWO Gen 2 and SWO

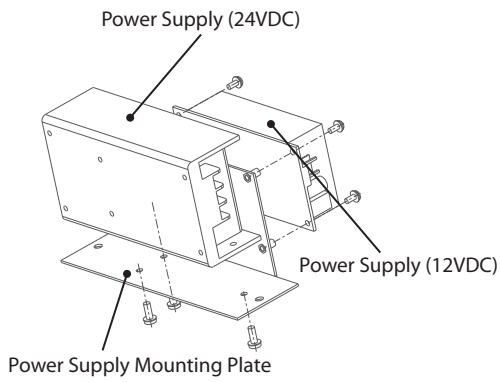

Figure A.12: Power Supply Assembly Detail

Mag Air Diverter Assembly Detail, DWO Gen 1, DWO Gen 2, and SWO

⚠ DANGER: Before removing or replacing any oven component, ensure the oven is removed from any power source (i.e., the breaker is turned off). Failure to do so can result in serious injury or death.

⚠ WARNING: Before removing or replacing any oven component, thoroughly read the safety instructions found at the front of this manual and in Oven Systems (Section 5) and Troubleshooting (Section 6). Adhere to all precautions and warnings outlined in these sections, as failure to do so could result in serious injury or death.

⚠ CAUTION: Before removing/installing any component, make sure it is disconnected from the wire harness (where applicable).

Item Description	Item Part #	Hardware Description	Hardware Part Number(s)
Capacitor, H.V.	100213	Bracket, Capacitor Screw, SH MTL, #8 x 1/2 Serrated PHTRH Screw, #6-32 x 1/2 LG, PPH, SS Nut, #6-32, Serr Hex FLNG, SS	104197 101688 (x2) 101570 100902
Diode, H.V.	100481	Screw, #8 x 1/2, PPH, PLT	101689 (x2)
Relay, K9	104179	Screw, #6 x 1/2, PPHD, DRL-PT, SS	101687 (x2)
Thermostat, 140F, Close on Rise	102087	Screw, #6 x 1/2, PPHD, DRL-PH, SS	101687 (x2)

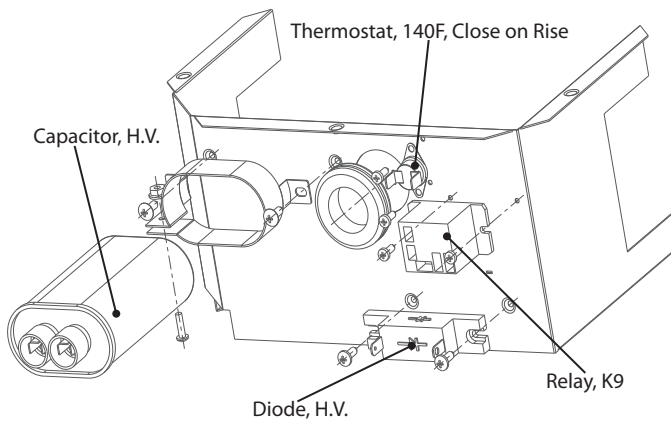

Figure A.13: Mag Air Diverter Assembly Detail, DWO Gen 1

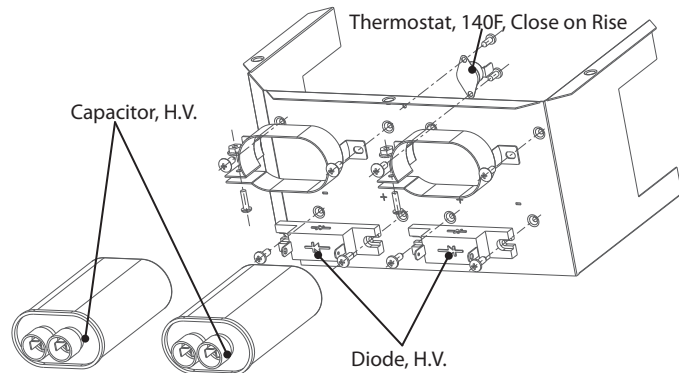

Figure A.14: Mag Air Diverter Assembly Detail, DWO Gen 2 and SWO

Relay and Relay/Power Assembly Detail, DWO Gen 1, DWO Gen 2, and SWO

⚠ DANGER: Before removing or replacing any oven component, ensure the oven is removed from any power source (i.e., the breaker is turned off). Failure to do so can result in serious injury or death.

⚠ WARNING: Before removing or replacing any oven component, thoroughly read the safety instructions found at the front of this manual and in Oven Systems (Section 5) and Troubleshooting (Section 6). Adhere to all precautions and warnings outlined in these sections, as failure to do so could result in serious injury or death.

⚠ CAUTION: Before removing/installing any component, make sure it is disconnected from the wire harness (where applicable).

Item Description	Item Part #	Hardware Description	Hardware Part Number(s)
M.O.V. Filter	RWD-9490	Standoff, #6-32 x 5/8, F/F, PLTD Screw, #6-32 x 1/4 LG, PPH, SS	101951 (x3) 101565 (x3)
Relay, K1	101281	Screw, #8-32 x 3/8, PPH, THD-Forming, PLT	104227 (x2)
Relay, K2	101273	Nut, #6-32, SERR HEX FLNG, SS	100902 (x2)
Relay, K3	101273	Nut, #6-32, SERR HEX FLNG, SS	100902 (x2)
Relay, K4	101273	Nut, #6-32, SERR HEX FLNG, SS	100902 (x2)
Relay, K5	101273	Nut, #6-32, SERR HEX FLNG, SS	100902 (x2)
Relay, K6	101273	Nut, #6-32, SERR HEX FLNG, SS	100902 (x2)
Relay, K7	101273	Nut, #6-32, SERR HEX FLNG, SS	100902 (x2)
Relay, K8	101273	Nut, #6-32, SERR HEX FLNG, SS	100902 (x2)
Relay, K9	104179	Screw, #6 x 1/2, PPHD, DRL-PT, SS	101687 (x2)
Terminal Block	104145	Screw, #8 x 3/4, PPHD, PLT-STL	104178 (x2)

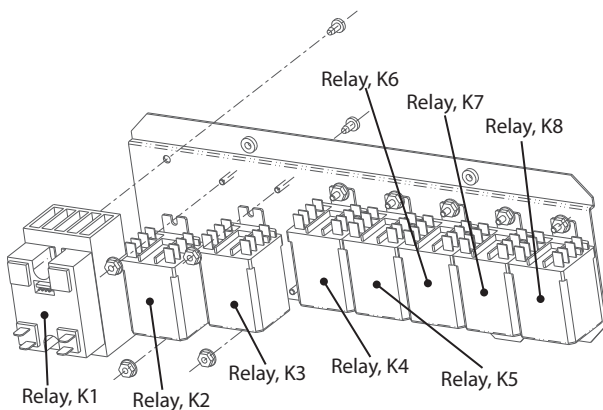

Figure A.15: Relay Assembly Detail, DWO Gen 1

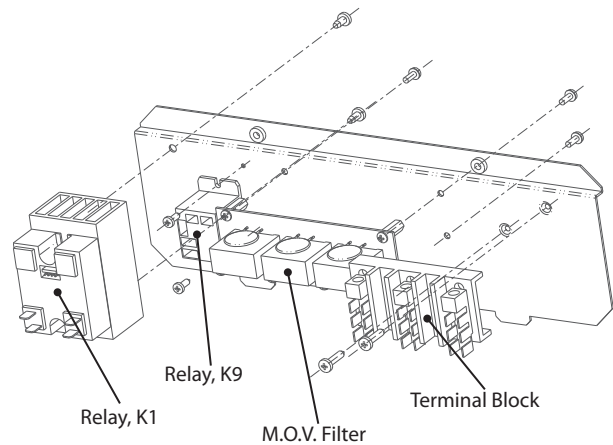

Figure A.16: Relay/Power Assembly Detail, DWO Gen 2 and SWO

Lower Electrical Compartment Detail, DWO Gen 1 and DWO Gen 2

⚠ DANGER: Before removing or replacing any oven component, ensure the oven is removed from any power source (i.e., the breaker is turned off). Failure to do so can result in serious injury or death.

⚠ WARNING: Before removing or replacing any oven component, thoroughly read the safety instructions found at the front of this manual and in Oven Systems (Section 5) and Troubleshooting (Section 6). Adhere to all precautions and warnings outlined in these sections, as failure to do so could result in serious injury or death.

⚠ CAUTION: Before removing/installing any component, make sure it is disconnected from the wire harness (where applicable).

Differentiating Between DWO Gen 1 and DWO Gen 2

Use the serial number to tell if the oven being serviced is a DWO Gen 1 or DWO Gen 2 oven. To view the serial number, open the Speedcook oven door and locate the serial plate (between the Speedcook oven door's hinges). If the serial number's first five characters are "TDO2D" (or "TSO2D" for SWO models), the oven is a Gen 2 oven. If the first five characters are NOT "TDO2D" (or "TSO2D"), the oven is a DWO Gen 1 oven.

Item Description	Item Part #	Hardware Description	Hardware Part Number(s)
Access Panel, EC, Lower	RWD-9127	Screw, SH MTL, #8 x 1/2 Serrated PHTRH	101688 (x3)
Bracket, Relay Attachment, Gen 1	RWD-9126	Screw, SH MTL, #8 x 1/2 Serrated PHTRH	101688 (x2)
Bracket, Relay Attachment, Gen 2	RWD-9126	Screw, SH MTL, #8 x 1/2 Serrated PHTRH	101688 (x2)
Cooling Fan, EC, Lower	104125	Screw, SH MTL, #8 x 1/2 Serrated PHTRH	101688 (x3)
Harness, H.V., Lower Oven, Gen 2	RWD-9539	None	None
Harness, L.V., Lower Oven, Gen 2	RWD-9541	None	None
Harness, Lower Oven	RWD-9408	None	None
Harness, Power, Lower, DWO	RWD-9429	None	None
High Limit Switch	102075	Screw, SH MTL, #8 x 1/2 Serrated PHTRH Screw, M4X 0.7 x 8, PPHD, INT Tooth, SS Bracket, High-Limit Switch, Lower	101688 (x4) 101672 (x2) RWD-9140
Latch Mechanism	RWD-9366	Screw, SH MTL, #8 x 1/2 Serrated PHTRH Bracket, Door Lock Support, GEN 1	101688 (x4) RWD-9595
Relay, K10	104202	Screw, #6 x 1/2, PPHD, DRL-PT, SS	101687 (x2)
Relay, K11	101281	Screw, SH MTL, #8 x 1/2 Serrated PHTRH	101688 (x2)
Relay, K12	101281	Screw, SH MTL, #8 x 1/2 Serrated PHTRH	101688 (x2)
Relay, K13	104179	Screw, #6 x 1/2, PPHD, DRL-PT, SS	101687 (x2)
Snubber, Electrical	RWD-9497	None	None
Terminal Block	104145	Screw, #8 x 3/4, PPHD, PLT-STL Bracket, Terminal Block Screw, SH MTL, #8 x 1/2 Serrated PHTRH	104178 (x2) RWD-9147 101688 (x2)
Thermostat, 160F, Close on Rise	104236	Screw, #6 x 1/2, PPHD, DRL-PT, SS	101687 (x2)
Thermostat, 280F, Open on Rise	104167	Screw, #6 x 1/2, PPHD, DRL-PT, SS	101687 (x2)
Wire, Canada, Black	RWD-9531	None	None
Wire, Canada, Orange	RWD-9530	None	None
Wire, Canada, Short	RWD-9529	None	None
Wire, L.V., P9 Conn., DWO	RWD-9430	None	None
Wire, Switch, Lower	RWD-9428	None	None

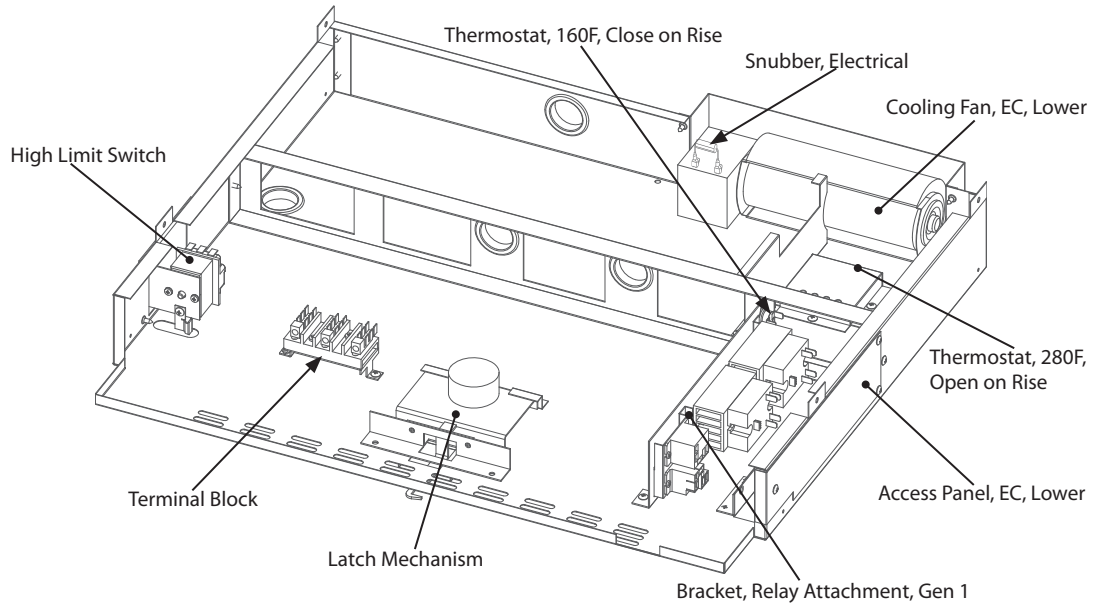

Figure A.17: Lower Electrical Compartment Detail, DWO Gen 1

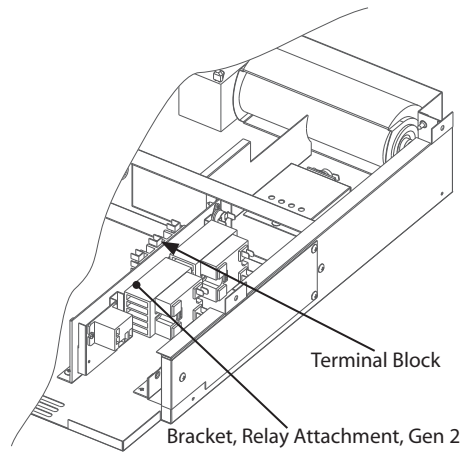

Figure A.18: Lower Electrical Compartment Detail, DWO Gen 2 (differences)

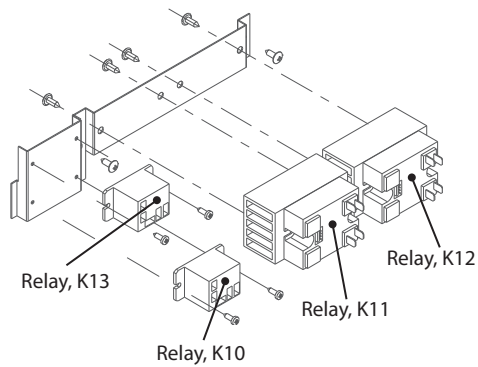

Figure A.19: Bracket, Relay Attachment Detail, Gen 1

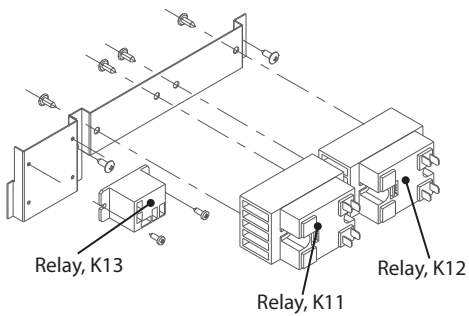

Figure A.20: Bracket, Relay Attachment Detail, Gen 2

Speedcook Oven Cavity Component Detail, DWO Gen 1, DWO Gen 2, and SWO

⚠ DANGER: Before removing or replacing any oven component, ensure the oven is removed from any power source (i.e., the breaker is turned off). Failure to do so can result in serious injury or death.

⚠ WARNING: Before removing or replacing any oven component, thoroughly read the safety instructions found at the front of this manual and in Oven Systems (Section 5) and Troubleshooting (Section 6). Adhere to all precautions and warnings outlined in these sections, as failure to do so could result in serious injury or death.

⚠ CAUTION: Before removing/installing any component, make sure it is disconnected from the wire harness (where applicable).

Item Description	Item Part #	Hardware Description	Hardware Part Number(s)
Blower Motor Controller	100446	Screw, SH MTL, #8 x 1/2 Serrated PHTRH	101688 (x4)
Blower Motor, Lower	RWD-9042	Nut, 1/4-20, Serrated Hex Flange, Plated Steel	100906 (x4)
Blower Motor, Upper	RWD-9040	Nut, 1/4-20, Serrated Hex Flange, Plated Steel	100906 (x4)
Catalytic Converter	RWD-9066	None	None
Cover, Blower Motors	RWD-9280	Screw, SH MTL, #8 x 1/2 Serrated PHTRH	101688 (x4)
Cover, Door Switch	RWD-9359	Screw, SH MTL, #8 x 1/2 Serrated PHTRH	101688 (x2)
Cover, Hinge Pocket	RWD-9472	Screw, SH MTL, #8 x 1/2 Serrated PHTRH	101688 (x2)
Cover, Motor End	RWD-9282	Screw, SH MTL, #8 x 1/2 Serrated PHTRH	101688 (x4)
Cover, Waveguide	RWD-9164	Screw, SH MTL, #8 x 1/2 Serrated PHTRH	101688 (x2)
Diverter	RWD-9283	None	None
Door Receiver	104123	Screw, 10-32 x 1/4 LG, PFLH 100 DEG, SS	101402 (x2)
Door Switch, LHS	RWD-9187	Screw, #6-32 x 1/2 LG, PPH, SS	101570 (x3)
Door Switch, RHS	RWD-9186	Screw, #6-32 x 1/2 LG, PPH, SS	101570 (x3)
Heater, Upper Oven (208V)	RWD-9394	Screw, SH MTL, #8 x 1/2 Serrated PHTRH	101688 (x8)
Heater, Upper Oven (240V)	RWD-9065	Screw, SH MTL, #8 x 1/2 Serrated PHTRH	101688 (x8)
Hinge Pocket, LHS	RWD-9098	Screw, SH MTL, #8 x 1/2 Serrated PHTRH	101688 (x3)
Hinge Pocket, RHS	RWD-9097	Screw, SH MTL, #8 x 1/2 Serrated PHTRH	101688 (x3)
Jetplate, Lower	RWD-9576	None	None
Jetplate, Upper	RWD-3017	Holder, Jet Plate Screw, SH MTL, #8 x 1/2 Serrated PHTRH	RWD-9404 (x2) 101688 (x4)
Lamp, Halogen, Upper Oven	RWD-3014	None	None
Microwave Stirrer Assembly	RWD-9275	Washer, Lock, #10 EXT TH, CRES Screw, #10-32 x 1/2, HEX, SERR FLG HD, SS	102260 104138
Rack	RWD-9167	None	None
RTD	RWD-9364	Screw, SH MTL, #8 x 1/2 Serrated PHTRH	101688 (x2)
Stirrer Shaft	RWD-9070	None	None
Stirrer, Coupling Hub	104133	None	None
Stirrer, Coupling Spider Insert	104134	None	None
Stirrer, Shaft Support	RWD-9077	Screw, #8-32 x 5/8 LG, SEMS, PPHD, SS	102962 (x4)
Stirrer, Stud Plate	RWD-9072	None	None
Support Rack, LHS	RWD-9165	None	None
Support Rack, RHS	RWD-9166	None	None
Thermostat, 270F, Open on Rise	104228	Screw, #6 x 1/2, PPHD, DRL-PT, SS	101687 (x2)

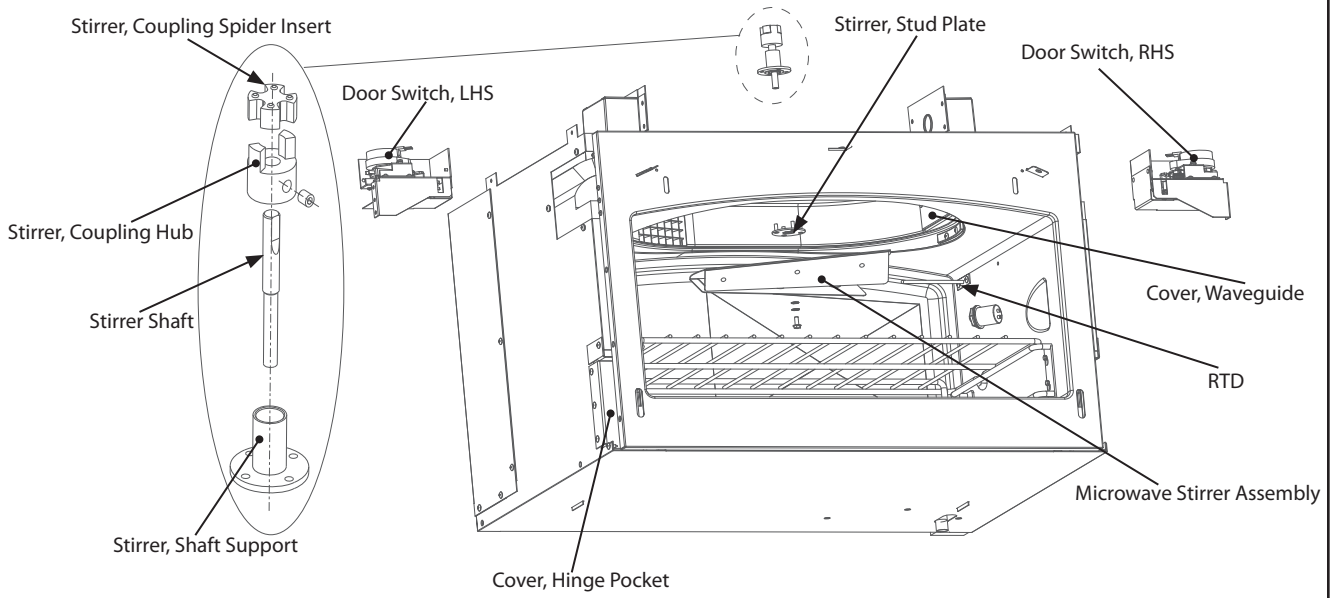

Figure A.21: Speedcook Oven Cavity Component Detail, Upper View

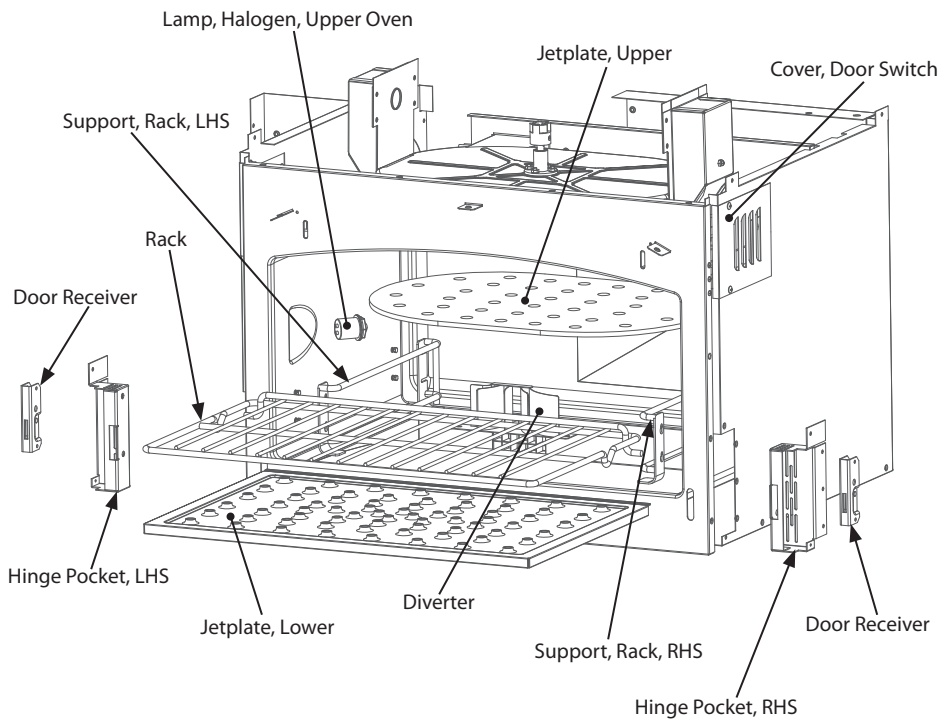

Figure A.22: Speedcook Oven Cavity Component Detail, Lower View

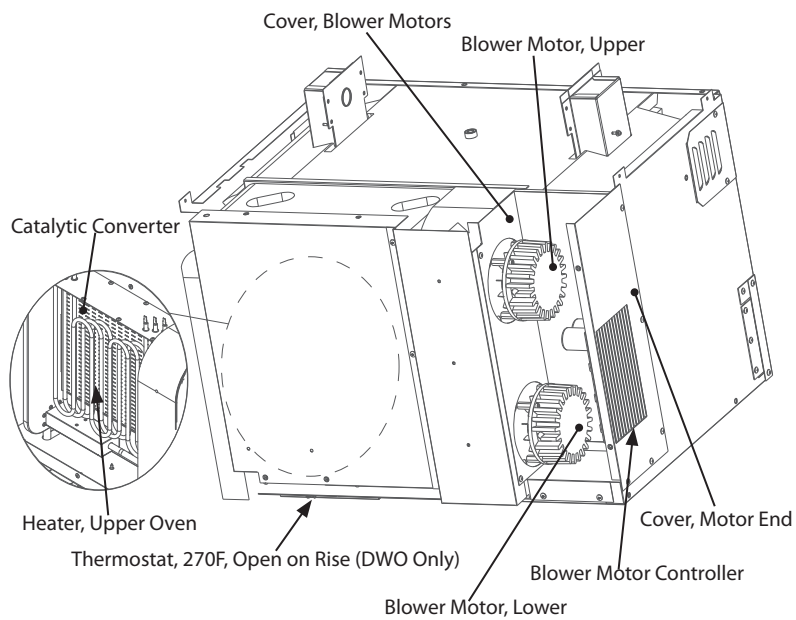

Figure A.23: Speedcook Oven Cavity Component Detail, Rear View

*This page intentionally
left blank.*

Lower Oven Cavity Component Detail, DWO Gen 1 and DWO Gen 2

⚠ DANGER: Before removing or replacing any oven component, ensure the oven is removed from any power source (i.e., the breaker is turned off). Failure to do so can result in serious injury or death.

⚠ WARNING: Before removing or replacing any oven component, thoroughly read the safety instructions found at the front of this manual and in Oven Systems (Section 5) and Troubleshooting (Section 6). Adhere to all precautions and warnings outlined in these sections, as failure to do so could result in serious injury or death.

⚠ CAUTION: Before removing/installing any component, make sure it is disconnected from the wire harness (where applicable).

Item Description	Item Part #	Hardware Description	Hardware Part Number(s)
Blade, Convection Fan	104169	Nut, Convection Fan Ring, Shim, Convection Fan	104170 104171
Bracket, Convection Fan	RWD-9238	None	None
Convection Fan	104158	Screw, #8-32 x 1/2, PPHD, INT SEMS, SS Nut, #8-32, HEX, SS	102923 (x3) 101000 (x3)
Convection Fan Assembly	N/A	Screw, SH MTL, #8 x 1/2 Serrated PHTRH	101688 (x8)
Cover, Bake Element	RWD-9242	Screw, SH MTL, #8 x 1/2 Serrated PHTRH	101688 (x5)
Cover, Hinge Pocket, Lower	RWD-9149	Screw, SH MTL, #8 x 1/2 Serrated PHTRH	101688 (x2)
Cover, Meat Probe	RWD-9128	Screw, SH MTL, #8 x 1/2 Serrated PHTRH	101688 (x2)
Cover, Rear, Lower Oven	RWD-9225	Screw, SH MTL, #8 x 1/2 Serrated PHTRH	101688 (x8)
Deflector, Broiler	RWD-9235	Screw, SH MTL, #8 x 1/2 Serrated PHTRH	101688 (x4)
Door Receiver	104123	Screw, 10-32 x 1/4 LG, PFLH 100 DEG, SS	101402 (x2)
Element, Bake, Concealed (208V)	RWD-9464	Screw, SH MTL, #8 x 1/2 Serrated PHTRH	101688 (x2)
Element, Bake, Concealed (240V)	RWD-9354	Screw, SH MTL, #8 x 1/2 Serrated PHTRH	101688 (x2)
Element, Broil (208V)	RWD-9462	Screw, SH MTL, #8 x 1/2 Serrated PHTRH	101688 (x4)
Element, Broil (240V)	RWD-9351	Screw, SH MTL, #8 x 1/2 Serrated PHTRH	101688 (x4)
Element, Convection (208V)	RWD-9463	Screw, SH MTL, #8 x 1/2 Serrated PHTRH	101688 (x2)
Element, Convection (240V)	RWD-9353	Screw, SH MTL, #8 x 1/2 Serrated PHTRH	101688 (x2)
Hinge Pocket, Lower, LHS	RWD-9119	Screw, SH MTL, #8 x 1/2 Serrated PHTRH	101688 (x3)
Hinge Pocket, Lower, RHS	RWD-9118	Screw, SH MTL, #8 x 1/2 Serrated PHTRH	101688 (x3)
Lamp, Halogen, Lower Oven	RWD-3016	None	None
Panel, Convection, Porcelain	RWD-9575	Screw, SH MTL, #8 x 1/2 Serrated PHTRH	101688 (x4)
Plate, Convection Fan	RWD-9237	Spacer, #8 x 5/16 OD x 1-1/2 LG, SS Screw, #8 x 2.00 PH MOD TRUSS SS	103326 (x4) 104184 (x4)
Rack Guide	RWD-9385	Screw, #8 x 3/8 PH MOD TRUSS, CRES	101682 (x2)
Rack, Lower Oven	RWD-9384	None	None
Rack, Roller, Lower Oven	RWD-9383	None	None
Receptacle, Meat Probe	104159	None	None
RTD	RWD-9364	Screw, #8 x 3/8 PH MOD TRUSS, CRES	101682 (x2)
Separator, Convection Fan	RWD-9223	Screw, SH MTL, #8 x 1/2 Serrated PHTRH	101688 (x4)
Snubber, Electrical	RWD-9497	None	None
Stand-Off, Broil Element	RWD-9215	Screw, SH MTL, #8 x 1/2 Serrated PHTRH	101688 (x2)
Stand-Off, Rear, Lower	RWD-9130	Screw, SH MTL, #8 x 1/2 Serrated PHTRH	101688 (x3)

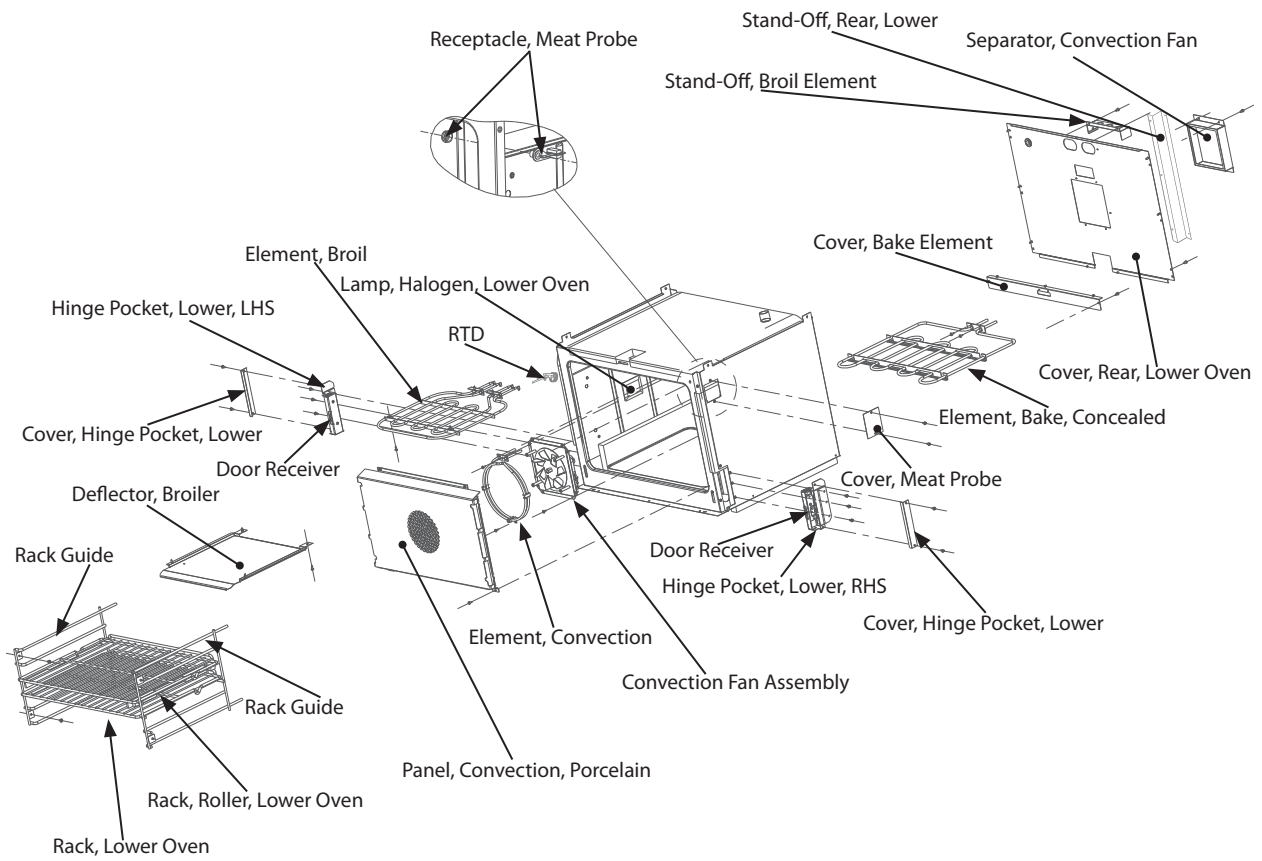

Figure A.24: Lower Oven Cavity Component Detail, DWO Gen 1 and DWO Gen 2

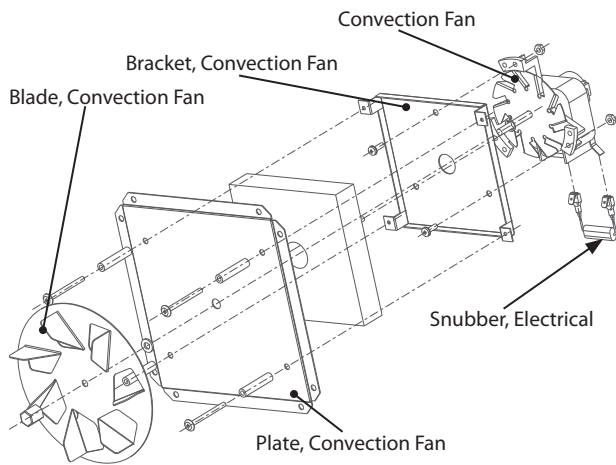

Figure A.25: Convection Fan Assembly Detail

*This page intentionally
left blank.*

For service or information:

Within North America call
866.447.3783

Outside North America call
+1 214.379.6000 or
Your Authorized Distributor



Accelerating the World of Cooking™

Part Number: RWD-9536 / Rev. B / October 2008
Country Code: NA/EU

Corporate Headquarters

Six Concourse Parkway, Suite 1900
Atlanta, Georgia 30328 USA
+1 678.987.1700 PHONE
+1 678.987.1750 FAX

Global Operations

4240 International Pkwy, Suite 105
Carrollton, Texas 75007 USA
+1 214.379.6000 PHONE
+1 214.379.6073 FAX

Customer Service: 866.447.3783
+1 214.379.6000

turbochef.com